



DUTXALIUM®

*Colección
2021/22*



DUTXALIUM®

ÍNDICE

Página 2: Introducción.

Página 3: Platos de ducha Gel Coat.

Página 11: Mamparas de baño standard aluminio.

Página 28: Mamparas de baño acero Inox. Steelbath.

Página 62: Muebles de baño.

Página 98: Encimeras.

Página 114: Lavabos y sanitarios.

Página 123: Griferías y duchas.

Página 154: Espejos led.

Página 222: Mamparas especiales a medida.

Página 267: Mamparas separadoras por módulos

(Spazia Fusión)

"DUTXALIUM NACE DE LA ALIANZA ENTRE LA EXPERIENCIA EN EL MUNDO DEL CONTRACT HOTELERO, EL MOBILIARIO DE BAÑO Y LA FUERZA E ILUSIÓN EMPRENDEDORA DE LA JUVENTUD.

NUESTRA EXPERIENCIA EN EL SECTOR DICTA EL RUMBO A SEGUIR Y VISUALIZANDO LAS VERDADERAS NECESIDADES DEL CLIENTE ACTUAL, EXIGIENDONOS A A CADA MOMENTO PODER OFRECER SIEMPRE LA MEJOR RELACIÓN CALIDAD/PRECIO DEL MOMENTO JUNTO AL SERVICIO MÁS INMEDIATO.

NUESTRO OBJETIVO ES EL DE NUESTRO CLIENTE, PODER AYUDAR EN TODO MOMENTO A CUMPLIR SATISFACTORIAMENTE CUALQUIER PROYECTO, AMOLDÁNDONOS AL MISMO Y CONTANDO SIEMPRE CON EL APOYO ALTAMENTE CUALIFICADO DE LOS CORRESPONDIENTES DEPARTAMENTOS TÉCNICOS DE NUESTROS FABRICANTES PARA PODER AFRONTAR LAS EXIGENCIAS DEL MISMO DE UNA FORMA TOTALMENTE PERSONALIZADA, CON LA CAPACIDAD DE FABRICAR CUALQUIER PRODUCTO DE NUESTRO CATÁLOGO TOTALMENTE PERSONALIZADO A MEDIDA.

ES UN ORGULLO PARA NOSOTROS PODER SER PARTE DE SU PROYECTO Y PODER AYUDARLE SATISFACTORIAMENTE.

NUESTRA ILUSIÓN SE UNE A LA FUERZA DE NUESTROS CLIENTES, CREANDO UN TRATO Y UN VINCULO PERSONAL LEJOS DEL FRÍO TRATO COMERCIAL, CREANDO ASÍ UNA ATENCIÓN PERSONALIZADA POCO VISTA ANTES EN EL SECTOR.

BIENVENIDOS A UNA NUEVA FORMA DE TRATO AL CLIENTE, BIENVENIDOS A DUTXALIUM..."

PLATOS DE DUCHA.

AKUA BATH

El cuarto de baño es la estancia más privada y personal. Este debe ser no solo un área de aseo sino un espacio de relajación y aislamiento del mundo exterior.

Akuabath le ofrece productos para diseñarlo.



LA DUREZA DE UN DIAMANTE. REVESTIMIENTO GEL-COAT ISO NPG SOLIDO Y DURADERO.

EL REVESTIMIENTO ES LA PARTE FUNDAMENTAL DEL PLATO DE DUCHA PORQUE CONSTITUYE LA MEJOR PROTECCION CONTRA FACTORES COMO: EL ENVEJECIMIENTO, LA DUREZA DEL AGUA, LA TEMPERATURA, LA LUZ, LOS AGENTES QUIMICOS, GOLPES, ETC.

ES UN REVESTIMIENTO A BASE DE GEL-COAT, PIGMENTOS NATURALES Y ADITIVOS ESPECIFICOS QUE CONFIEREN A NUESTROS PLATOS PROPIEDADES DE RESISTENCIA QUE VAN MAS ALLÁ DE LOS ESTANDARES ENCONTRADOS EN EL MERCADO.

EL GEL-COAT ES GENERALMENTE USADO EN APLICACIONES DONDE LAS PIEZAS ESTARAN ENFRENTADAS A LAS CONDICIONES MAS DURAS COMO SON LA NAUTICA, PISCINAS CLIMATIZADAS O SECTOR SANITARIO.

CON SUS 600 MICRAS DE GROSOR, NUESTRO REVESTIMIENTO DE GEL-COAT ES CASI 10 VECES MAS GRUESO QUE UNA PINTURA SANITARIA.

SU FUSION CON LA MASA HACE DEL PLATO DE DUCHA UNA PIEZA UNICA, APORTANDO UNA RESISTENCIA AUMENTADA A:

- LOS RAYOS UVA Y A LA HIDROLISIS
- A LOS PRODUCTOS QUIMICOS
- Y A LOS IMPACTOS Y ROCES

ES TAMBIEN EL QUE LE DA SU ASPECTO ESTRUCTURADO Y SU CALIDAD ESTETICA.

PUEDE IMITAR A LA PERFECCION MATERIALES NATURALES COMO LA PIZARRA, LA PIEDRA O LA ARENA.

ADEMAS EL GEL-COAT ES CÁLIDO AL TACTO Y PERFECTAMENTE ANTI-DESLIZANTE. ESTOS SON OTROS DE SUS PRINCIPALES VALORES ADICIONALES.

NUESTROS PLATOS SON TOTALMENTE RECORTABLES CENTIMETRO A CENTIMETRO, PERMITIENDO ASI VENIR DE FABRICA CON LA MODIFICACION NECESARIA PARA SU OBRA (CORTE PARA PILAR, CORTE A GRADOS, ETC) CON LA MEDIDA EXACTA A NECESIDAD DEL CLIENTE.



LUCÍA

PLATO



OPCIÓN PLANO

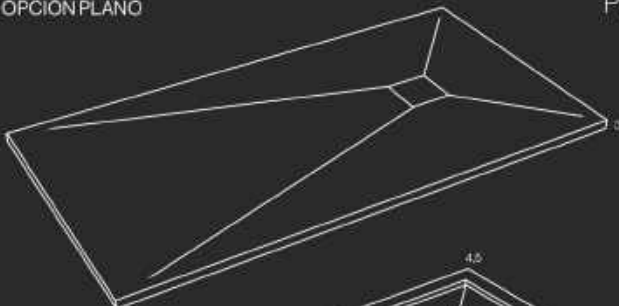

OPCIÓN ENMARCADO

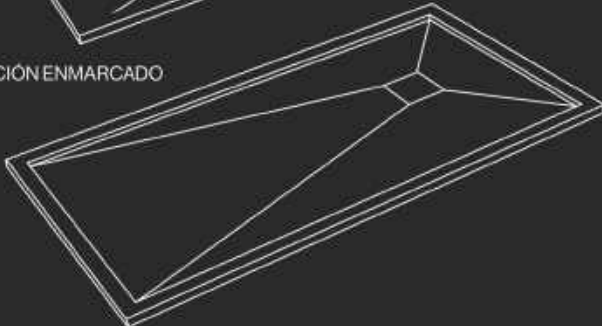

PLATO **LUCÍA**

Acabados Standard

Bianco Ral 9003	Ceriseo Ral 7042
Crema Ral 1013	Africaino Ral 7015
Beige Ral 1015	Chocolate Ral 8017
Musgo Ral 1019	Negro Ral 9005

Acabados Carta



Válvula desagüe



EMMA

PLATO



OPCIÓN PLANO

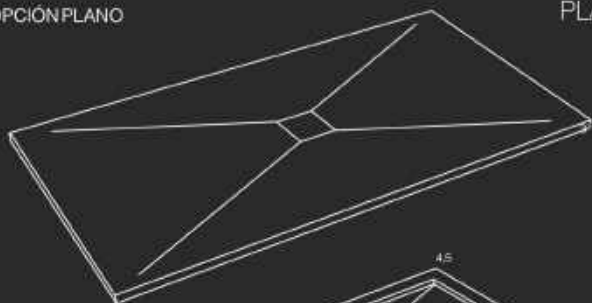

OPCIÓN ENMARCADO

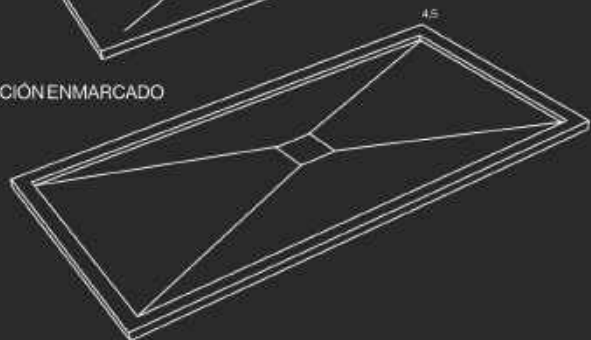

PLATO **EMMA**

Acabados Standard

Blanco Ral 9003	Grigio Ral 7043
Creama Ral 1013	Acacia Ral 7015
Beige Ral 1095	Chocola Ral 8017
Verde Ral 1019	Negro Ral 9005

Acabados Carta



Válvula desagüe



Antibacteriano



Antioxidante
class C - 3



Fácil
limpieza



Armada



Miso
Cotizada

Otras Opciones

PANELES

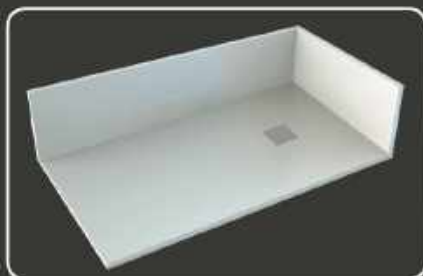

70	60	90	120	150	180	210
80	60	90	120	150	180	210
90	60	90	120	150	180	210
100	60	90	120	150	180	210



COLORES

Blanco Ral: 9003	Crema Ral: 1013	Beig Ral: 1015	Moka Ral: 1019
Cemento Ral: 7042	Antracita Ral: 7015	Chocolate Ral: 8017	Negro Ral: 9005

KIT DE REPARACIÓN



KIT pequeño 250 gr. **KIT grande** 500 gr.

RAMPA



COLORES

Blanco Ral: 9003	Crema Ral: 1013	Beig Ral: 1015	Moka Ral: 1019
Cemento Ral: 7042	Antracita Ral: 7015	Chocolate Ral: 8017	Negro Ral: 9005

Medida desde 60 cm. hasta 210 cm.
Incremento por elección en carta de color RAL.
Precio metro lineal

VÁLVULAS

90 CM.

60 CM.



VÁLVULAS CLICK CLACK

CROMO

COLOR

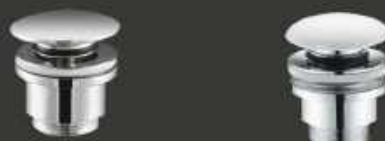

SIFONES

LATÓN CROMADO LATÓN COLOR



PLATOS SERIE VENUS



La serie VENUS es una alternativa al plato clásico que permite tener su válvula casi oculta lo más próxima a la pared, dejando la superficie pisable del plato totalmente libre.

Gracias a su pendiente y a la situación de su válvula, este modelo garantiza un perfecto flujo y evacuación del agua.

Permite corte en tres de sus lados.

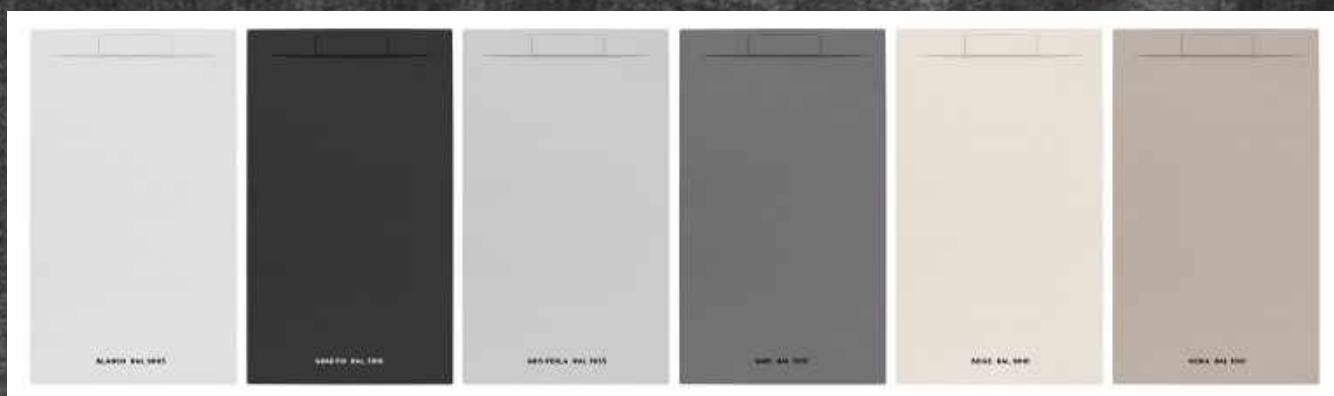

PLATOS SERIE VENUS



PLATOS SERIE VENUS



La serie VENUS está fabricada con una composición de resina isoftálica, formulada especialmente para aplicaciones donde se requiere máxima resistencia a los agentes químicos y a la temperatura.

Contiene un recubrimiento utilizado en la imprimación de color neopentilcol.

Este Gel-Coat se caracteriza por:

- Nula absorción de agua.
- Dureza en la escala de Barcol de 45.
- Resistencia al rayado.
- Anti bacterias.
- Resistencia al deslizamiento.
- Resistencia a variaciones de temperatura.
- Resistencia a agentes químicos.
- Personalizable a medida y a color Ral.



MAMPARAS DE BAÑO DE ALUMINIO.



*"QUEREMOS QUE LA MAMPARA
SEA UN ARTÍCULO
PERSONALIZADO PARA CADA
AMBIENTE, DANDO VIDA Y ESTILO
PROPIO A SU BAÑO."*

*"UN CLIENTE, UN PROYECTO, UN
OBJETIVO, UN RETO. SU
SATISFACCIÓN..."*

Nuestra recompensa se encuentra en el
esfuerzo y no en el resultado. Un esfuerzo total
es una victoria completa.

(Mahatma Gandhi)

Tratamiento Glass-Protect

Este producto es un compuesto líquido diseñado para el tratamiento superficial de cualquier tipo de vidrio, proporciona una protección duradera contra las influencias climatológicas y ambientales; agua, humo, polvo, agentes químicos, etc. Una de las propiedades principales del producto es el carácter protector que recubre la superficie aplicada la cual repele el agua creando pequeñas gotitas. Haciendo la limpieza mucho más sencilla utilizando sólo agua y un detergente suave o una bayeta de microfibras. Dicho polímero transparente cubre el poro superficial del vidrio, evitando la acumulación de agentes atmos-

féricos y condiciones agresivas que degradan la calidad del vidrio. La acción del agua sobre el vidrio actúa como elemento limpiador; resbalando sobre la superficie y arrastrando las partículas que estuviesen adheridas al vidrio, como el polvo, jabón, etc. Su duración está garantizada por 5 años en interiores. Está diseñado para su aplicación en escaparates, mamparas de baño, muros cortinas y vidrios fachada en general y deberá ser realizada durante el proceso de fabricación, no pudiendo aplicarse sobre un vidrio ya instalado.

Tratamiento sin Glass-Protect



Tratamiento con Glass-Protect

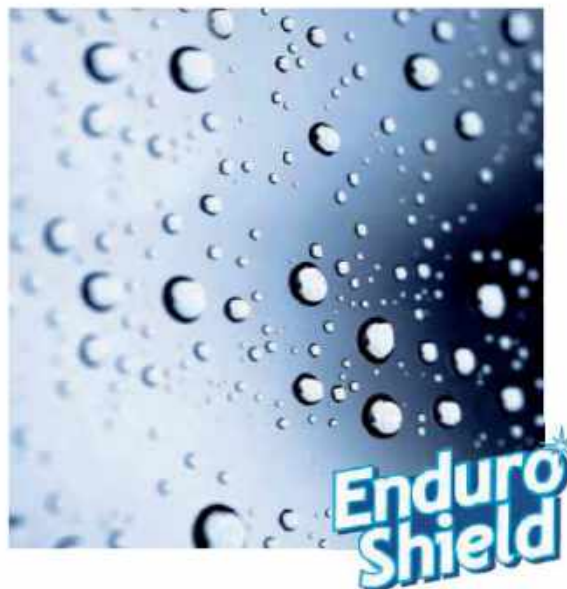

Características del vidrio templado

Se denomina vidrio templado o vidrio tensionado que sometidos a un proceso de templado aumenta su resistencia a esfuerzos de origen térmico y mecánico. El proceso de templado consiste en calentar uniformemente hasta una temperatura superior a 650° para luego enfriarlo bruscamente, soplando aire frío sobre sus caras. Una vez templado, cualquier manufactura que se realizara, produciría su rotura.

Es por ello que todas las muescas, orificios, etc. deberán realizarse previamente al templado. El vidrio templado está considerado como un vidrio de seguridad; su uso es recomendado en diversas áreas susceptibles al impacto humano. Esto debido a que, en caso de rotura, el vidrio se desintegra en pequeños fragmentos de aristas redondeadas, que no causan heridas cortantes de consideración.

LIMPIEZA

Limpiar con una solución de agua tibia y un poco de jabón neutro. Aclarar con agua utilizando para ello una esponja muy suave o una gamuza.

CARIBE



CARACTERÍSTICAS

Mampara frontal ducha de tres hojas correderas desmontables, fabricadas en aluminio de corte recto en lacado o anodizado. Accesorios en el mismo color que la perfilera, excepto en colores ral. Carril inferior guiador auto-limpiable de "sistema patentado". Con placas acrílicas de 2,2 mm de espesor (en Agua y Quadrat) o vidrio templado hasta 4 mm de espesor (en Incoloro, Mate, Carglass, Parisol color, Master carré, Grabado a la arena e Hydrographics). Rodamientos de bolas en acero inoxidable en la parte superior compensable en altura 3 mm y perfil tubular de compensación hasta 10 mm por cada lado, fijación por expansores laterales y cierre magnético oculto en el interior de la hoja tirador.

Altura estándar de 190,0 cm.

Este modelo no permite invertir las hojas. Nota: Si lleva fijo, fijación al frontal clipable. Reversible a derecha e izquierda.

		AL aluminio			
Altura estándar 190,0 cm	Mampara corredera	Aluminio	Espesor acrílico 2,2 mm	Espesor vidrio 4 mm	Sistema antivuelco
Liberación de hojas	Compensación por lado 10 mm	Fácil instalación	Fijación sin taladrar pared	Tratamiento Glass Protect Gratts	NIVEL 1 Estanqueidad



Colección Mamparas
Ducha/Bañera a medida

Revista del Baño Edición 3ª



CARES



CARACTERISTICAS

Mampara frontal ducha de hoja corredera + hoja fija fabricada en aluminio de corte recto en lacado o anodizado. Accesorios en el mismo acabado que la perflería, excepto en colores ral. Con placas acrílicas de 2,2 mm de espesor (en Agua y Quadrat) o vidrio templado hasta 4 mm de espesor (en Incoloro, Mate, Carglass, Parsol color, Master carré, Grabado a la arena e Hidrographics). Rodamientos de bolas en acero inoxidable en la parte superior e inferior compensables en altura 3 mm. Perfil de compensación hasta 30 mm por cada lado, fijación por extensores laterales y cierre magnético en el lateral.

Altura estándar de 190,0 cm.

Nota: Indique la posición del fijo, derecha e izquierda.

 190,0 cm Altura estándar	 Mampara corredera	AL aluminio Aluminio	 2,2 mm Espesor acrílico	 4 mm Espesor vidrio
 Mampara reversible	 30 mm Compensación por lado	GLASS PROTECT Tratamiento Glass Protect Opcional	 Nivel 1 Estanqueidad	

hidroglass[®]
mercado barcelonés

Colección
Mamparas
Ducha/Bañera a medida
Revista del Baño Edición 3^ª

LYNO



ACABADO DEL ALUMINIO

(Ver Pág. 47)

ESQUEMA MODELO



Blanco

Plata Brillo

Acero Inox.

Cromo



Posibilidad
acabado
Madera
Nogal



CARACTERÍSTICAS

Mampara frontal ducha de dos hojas seccionadas abatibles en vidrio templado de 6 mm de espesor, (en Incoloro, Mate, Carglass, Parsol color, Master carré, Grabado a la arena e Hidrographics). Perfilera de aluminio hasta 1,7 mm de espesor en lacado o anodizado. Sistema de autoelevación en hojas abatibles, ideal para personas con movilidad reducida o niños. Su sistema de hoja abatible se divide en dos partes, para que la parte de arriba pueda ser abierta y de esta forma acceder al interior del baño. Accesorios en el mismo color que la perfilera, excepto en colores ral y acero inox. Perfil de compensación hasta 15 mm, fijación por extensores laterales. Cierre magnético de goma imán translúcida en el lateral, junta de goma inferior en inglete y perfil base de aluminio para una mayor estanqueidad. Diseño exclusivo de tirador pomo, en acabado cromo.

Altura estándar de 188,3 cm.

Nota: Indicar la posición del montaje de las puertas seccionadas, derecha e izquierda.

hidroglass®
mamparas bañadores

Colección
Mamparas

Ducha/Bañera a medida

Revista del Baño Edición 3ª



KABUL



DETALLES



195,3 cm

Altura estándar



Mampara abatible



Aluminio



Espesor vidrio



Fácil instalación



Español: Opcional



Tratamiento Glass Protect Opcional



NIVEL 3 Estanqueidad

CARACTERISTICAS

Mampara frontal ducha en vidrio templado de 6 mm de espesor (en Incoloro, Mate, Carglass, Parsol color, Master carré, Grabado a la arena e Hydrographics) o en vidrio templado de 8 mm de espesor (en Incoloro, Mate, Parsol color, Master carré, Grabado a la arena e Hydrographics). Perifería de aluminio hasta 1,5 mm de espesor anodizado cromo. Accesorios en acabado plata con partículas metálicas. Perfil de compensación hasta 5 mm, fijación por extensor lateral. Junta de goma inferior para una mayor estanqueidad.

Altura estándar de 195,0 cm.

Nota: Indique la posición del montaje, derecha e izquierda.



NEDE



CARACTERÍSTICAS

Mampara frontal ducha de hoja corredera + hoja fija en vidrio templado de 6 mm de espesor (en incoloro y Grabado a la arena G01, G02, G03, G04, G05, G20, G22 Y G24). Equipada con cierre magnético de goma imán translúcida en el lateral y perfiles de aluminio anodizado cromo en guía superior y "u" lateral, con perfil base para una mayor estanqueidad y accesorios en Zamak acabado cromo. Rodamientos tándem compensable en altura 5 mm, en la parte superior. Diseño exclusivo de tirador uñero en hoja corredera, acabado cromo. Sistema antivuelco de hoja.

Altura estándar de 195,0 cm.

Nota: Indique la posición del fijo, derecha e izquierda. Para este modelo es necesaria una perfecta alineación de las paredes.



hidroglass®
independiente Barcelona

Colección
Mamparas
Ducha/Bañera a medida
Revista del Baño Edición 3ª



EDEN



195,0 cm Altura estándar	Mampara corredera	AL aluminio	6 mm Espesor vidrio	Sin guía inferior	Sistema antivuelco
Fácil instalación	Espejo Mirador Opcional	Cierre de imán	GLASS PROTECT Tratamiento Glass Protect Gratis	Uñero	Tenedor uñero OPCIONAL
NIVEL 2 Estanqueidad					

CARACTERÍSTICAS

Mampara frontal ducha de hoja corredera + hoja fija en vidrio templado de 6 mm de espesor (en incoloro, Mate, Carglass, Parsol color, Master carré y Grabado). Perfilería de aluminio en anodizado cromo, accesorios en Zamak acabado cromo. Rodamientos tándem compensable en altura 5 mm, en la parte superior. Equipada con cierre magnético de goma imán translúcida y perfil base de aluminio cromo para una mayor estanqueidad. Diseño exclusivo de asa tirador doble de 255mm, acabado cromo. Sistema antivuelco de hoja. Altura estándar de 195,0 cm.

Nota: Indique la posición del fijo, derecha e izquierda. Para este modelo es necesario una perfecta alineación de las paredes.

hidroglass®
microbatería baño/ducha 2

Colección
Mamparas
Ducha/Bañera a medida
Revista del Baño Edición 3ª

TIRSO

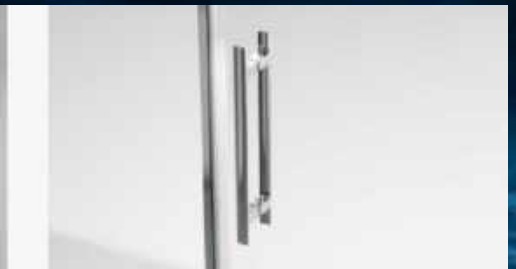
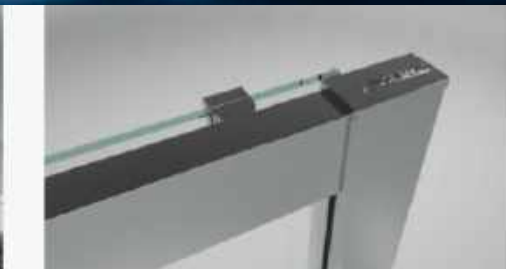

CARACTERÍSTICAS

Mampara frontal ducha de hoja corredera + hoja fija en vidrio templado de 6 mm de espesor (en Incoloro, Mate, Carglass, Parsol color, Master carré, Grabado a la arena e Hidrographics). Perfilería de aluminio en lacado o anodizado, accesorios en ABS de alto impacto, acabado cromo. Rodamientos tán-dem compensable en altura 5 mm, en la parte superior. Perfil de compensación hasta 20 mm por cada lado, fijación por extensores laterales. Equipada con goma translúcida y perfil base de aluminio para una mayor estanqueidad. Diseño exclusivo de tirador asa doble de 255 mm, acabado cromo.

Altura estándar de 195,0 cm.

Nota: Indique la posición del fijo, derecha e izquierda.

hidroglass®
mamparas baño/ducha

Colección
Mamparas

Ducha/Bañera a medida

Revista del Baño Edición 3ª



ODER

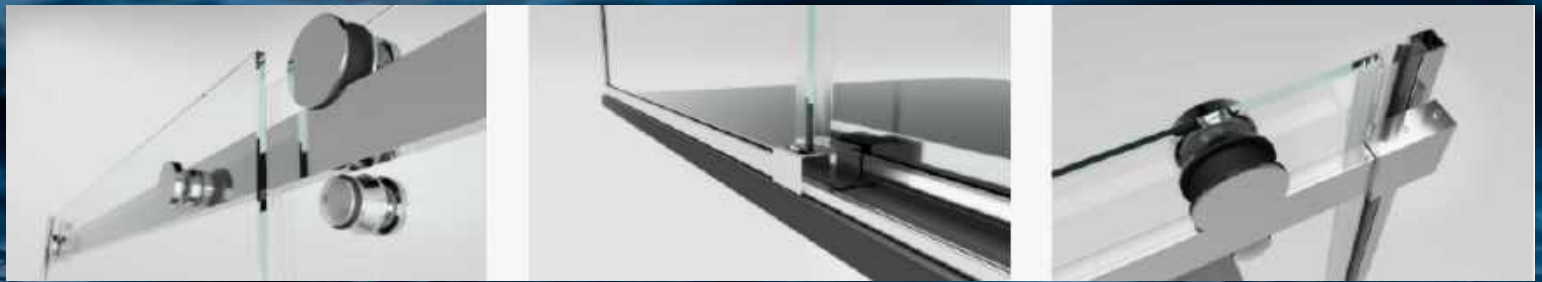

CARACTERISTICAS

Mampara frontal ducha de hoja corredera + hoja fija en vidrio templado de 8 mm de espesor (en Incoloro, Mate, Parsol color, Master carré y Grabado). Perfil rectangular de acero pulido brillo de 2 mm de espesor en guía superior. Accesorios en acero pulido brillo y rodamientos vistos al aire. Equipada con cierre magnético de goma imán translúcida en el lateral y perfil de aluminio cromo para una mayor estanqueidad. Diseño exclusivo de tirador uñero de acero inoxidable en la hoja corredera, acabado cromo.

Altura estándar de 195,0 cm.

hidroglass®
Incorporat barcoludico

Colección
Mamparas

Ducha/Bañera a medida

Revista del Baño Edición 3*





CARACTERÍSTICAS

Mampara frontal ducha de dos hojas correderas en vidrio templado de 6 mm de espesor (en Incoloro, Mate, Carglass, Parsol color, Master carré, Grabado a la arena e Hidrographics). Perfilera de aluminio en lacado o anodizado. Rodamientos tándem compensable en altura 5 mm, en la parte superior. Perfil tubular de compensación hasta 10 mm por cada lado, fijación por extensores laterales. Equipada con cierre magnético de goma imán translúcida en los laterales. Diseño exclusivo de tirador asa doble de 255 mm, en acabado cromo.

Altura estándar de 195,0 cm.

Nota: Para terminación en cromo la altura máxima de fabricación será de 195,0 cm.



hidrogl[®]ass
mamparas bañoducha

Colección
Mamparas
Ducha/Bañera a medida
Revista del Baño Edición 3[®]



HUDSON



CARACTERISTICAS

Mampara frontal ducha de tres hojas correderas en vidrio templado de 6 mm de espesor (en Incoloro, Mate, Carglass, Parsol color, Master carré, Grabado a la arena e Hidrographics). Perfilera de aluminio en lacado o anodizado. Rodamientos tándem compensable en altura 5 mm, en la parte superior. Perfil tubular de compensación hasta 10 mm por cada lado, fijación por extensores laterales. Equipada con cierre magnético de goma imán translúcida en los laterales. Diseño exclusivo de tirador asa doble de 255 mm, en acabado cromo.

Altura estándar de 195,0 cm.

Nota: Para terminación en cromo la altura máxima de fabricación será de 195,0 cm.

hidroglass®
mamparas baño duchas

Colección
Mamparas
Ducha/Bañera a medida

Revista del Baño Edición 3ª

Altura estándar 195,0 cm	Mampara corredera	Aluminio	Espesor vidrio 6 mm	Sistema antirruído
Compensación lateral 10 mm	Tratamiento Glass Protect Gratis	Espejo Mirador Opcional	Nivel 1 EsRanquetiel	



ESLA



CARACTERÍSTICAS

Mampara frontal ducha de hoja corredera + hoja fija en vidrio templado de 6 mm de espesor (en Incoloro, Mate, Carglass, Parsol color, Master carré, Grabado a la arena e Hidrographics). Perfilera de aluminio en lacado o anodizado, accesorios en ABS de alto impacto, acabado cromo. Rodamientos tándem compensable en altura 5 mm, en la parte superior. Perfil de compensación hasta 20 mm por cada lado, fijación por extensores laterales. Equipada con goma translúcida y perfil base de aluminio para una mayor estanqueidad. Diseño exclusivo de tirador asa doble de 255 mm, acabado cromo.

Altura estándar de 195,0 cm.

Nota: Indique la posición del fijo, derecha e izquierda.

hidroglass®
mamparas baño ducha

Colección
Mamparas
Ducha/Bañera a medida
Revista del Baño Edición 3ª

 195,0 cm Altura estándar	 Mampara corredera	 AL aluminio	 6 mm Espesor vidrio	 Sistema antirruído	 Liberación de hojas	 Carril ajustable
 10 mm Compensación por lado	 Fácil instalación	 Español / Inglés / Opcional	 GLASS PROTECT Tratamiento Glass Protect Opcional	 Tirador doble OPCIONAL	 NIVEL 1 Estanqueidad	

SIRIA

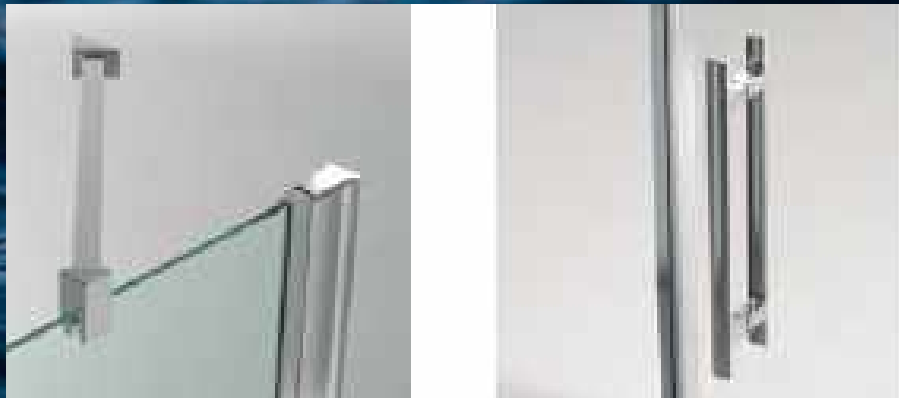

CARACTERÍSTICAS

Mampara frontal ducha de fijo continuo + hoja abatible + fijo continuo en vidrio templado de 6 mm de espesor (en Incoloro, Mate, Carglass, Parsol color, Master carré, Grabado a la arena e Hidrographics). Periferia de aluminio hasta 1,7 mm de espesor en anodizado cromo. Sistema de bisagra elevable vidrio a vidrio con giro 90° exterior, acabado en cromo. Accesorios en acabado plata con partículas metálicas. Perfil de compensación hasta 20 mm por cada lado, fijación por extensores laterales. Cierre magnético de goma imán translúcida sobre el fijo. Juntas de goma inferior en inglete y perfil base de aluminio para una mayor estanqueidad. Diseño exclusivo de tirador asa doble de 255 mm, acabado cromo.

Altura estándar de 195,0 cm.

Nota: Indique la posición del montaje de la puerta, derecha e izquierda.

hidroglass®
reparat barcelona

Colección
 Mamparas
 Ducha/Bañera a medida

Revista del Baño Edición 3ª



 195,0 cm Altura estándar	 Mampara abatible	 AL aluminio	 6 mm Espesor vidrio	 20 mm Compensación por lado
 Fácil instalación	 Espejo Mirador Opcional	 GLASS PROTECT	 NIVE 3 Estanqueidad	

CANCUN



CARACTERÍSTICAS

Mampara frontal ducha de hoja abatible en vidrio templado de 6 mm de espesor (en Incoloro, Mate, Carglass, Parsol color, Master carré, Grabado a la arena e Hidrographics). Perfilería de aluminio hasta 1,7 mm de espesor en lacado o anodizado. Sistema de autoelevación en hoja abatible, accesorios en el mismo acabado que la perfilaría, excepto en colores ral y acero inox. Perfil de compensación hasta 15 mm, fijación por extensores laterales. Cierre magnético de goma imán translúcida en el lateral. Junta de goma inferior en inglete y perfil base de aluminio para una mayor estanqueidad. Diseño exclusivo de tirador asa doble de 255 mm en acabado cromo.

Altura estándar de 188,3 cm.

Nota: Indique la posición del montaje de la puerta, derecha e izquierda.

hidroglass®
interior exterior baño ducha

Colección Mamparas
 Ducha/Bañera a medida
 Revistas del Baño Edición 3ª

 188,3 cm Altura estándar	 Mampara abatible	 AL aluminio Aluminio	 6 mm Espesor vidrio	 15 mm Compensación lateral
 Fácil instalación	 Espejo Mirador Opcional	 Cierre de imán	 GLASS PROTECT Tratamiento Glass Protect Opcional	 NIVE. 3 Estanqueidad



CARACTERÍSTICAS

Mampara frontal ducha de hoja abatible en vidrio templado de 6 mm de espesor (en Incoloro, Mate, Carglass, Parsol color, Master carré, Grabado a la arena e Hydrographics) o de 8 mm de espesor (en Incoloro, Mate, Parsol color, Master carré, Grabado a la arena e Hydrographics). Bisagra de latón vidrio a pared con giro de 180° acabado cromo. Junta de goma lateral e inferior y perfil base de aluminio para una mayor estanqueidad. Cierre magnético de goma imán translúcida en el lateral. Diseño exclusivo de pomo tirador doble, acabado en cromo.

Altura estándar de 195,0 cm

Nota: Indicar la posición del montaje de la puerta, derecha e izquierda.

hidroglass®
INTEGRAL BANCALUZZA

Colección
 Mamparas
 Ducha/Bañera a medida

Revista del Baño Edición 3ª

		LA Latón		
Altura estándar 195,0 cm	Mampara abatible	Latón	Espesor vidrio 6 mm	Espesor vidrio 8 mm
			GLASS PROTECT	
Mampara reversible	Espesor Master Opcional	Cierre de imán	Tratamiento Glass Protect Opcional	VEL 5 Estanqueidad

MAMPARAS A
MEDIDA EN ACERO
INOXIDABLE.



Consolidados como empresa líder ofreciendo calidad a precios asequibles. Un equipo preparado para los retos de ésta época y la ilusión de crear productos únicos y diferenciados en el mercado de las mamparas . Con más de 30 años de experiencia en el sector de nuestro equipo humano, le aseguramos calidad y garantía en todos nuestros productos.

Nuestro productos presumen de diseño y durabilidad, pero en constante innovación para poder ofrecerle la mejor relación calidad/precio del mercado.

Nuestra materia prima, el mejor acero, nos permite estar en el top del mercado.

Siempre la mejor calidad, siempre SteelBath.

La calidad nunca es un accidente; siempre es el resultado de un esfuerzo de la inteligencia.

(John Ruskin)



A2F



Frontal ducha 1 hoja fija 1 hoja corredera

ACERO INOXIDABLE





A4F

anti
CAL
INCLUIDO



6 mm

1950 mm



10 días
warranty

Frontal 2 hojas fijas 2 hojas correderas





B4F



Frontal ducha 2 hojas fijas y 2 hojas
correderas



C2F



Frontal ducha 1 hoja fija 1 hoja
corredera



C4F



Frontal 2 hojas correderas y 2 hojas fijas



D2F



Frontal ducha 1 hoja fija y 1 hoja corredera

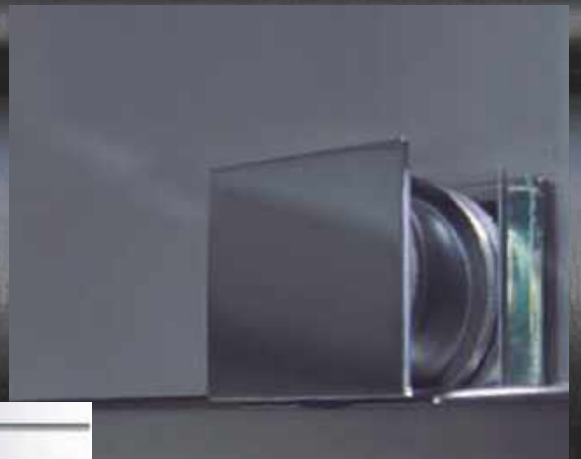



D4F



Frontal 2 hojas correderas y 2 hojas fijas

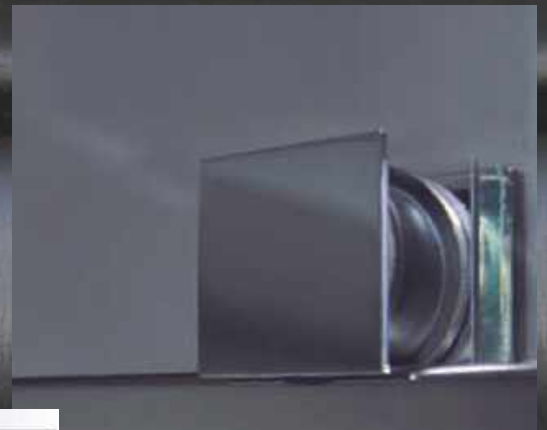



E2F



Frontal ducha 1 hoja fija y 1 hoja
corredera



E4F



Forntal 2 hojas correderas y 2 hojas fijas



H2



Frontal ducha 2 hojas correderas



H3



Frontal ducha 3 hojas correderas



K2F

anti
CAL
INCLUIDO



6 mm

1950 mm



10 días
estándar

estándar:
4 días

Frontal ducha 1 hoja fija y 1 hoja
corredera



A2F



CATEGORÍAS: ABATIBLES, FRONTALES

ETIQUETA: A2F



F1

anti
CAL
INCLUIDO



6 mm

1950 mm

10 días
MEDIDA

Frontal ducha 1 hoja abatible 90°



F2F



Frontal ducha 1 hoja sbatible 90° y 1 hoja fija



F4



Frontal ducha 2 hojas abatibles 90° y 2
hojas fijas



G1



Frontal ducha 1 hoja abatible 180°



G2



Frontal ducha 2 hojas abatibles 180°



G2F



Frontal ducha 1 hoja abatible 180° y 1 hoja fija



G3F



Frontal ducha 1 hoja abatible 180° y 2 hojas fijas



G4F



Frontal ducha 2 hojas abatibles 180° y
2 hojas fijas



K2K

anti
CAL
INCLUIDO



8 + 6
mm

1950
mm

estándar
4 días

Frontal ducha 1 hoja abatible 180° y 1
hoja fija



E2



Frontal ducha 2 hojas plegables



K1

anti
CAL
INCLUIDO



8
mm

1950
mm

estándar
48h>>

Frontal 1 hoja fija



K1H

anti
CAL
INCLUIDO



8
mm

1950
mm

10
días
MEDIDA

Frontal ducha 1 hoja fija



C4FA



Angular 2 hojas fijas y 2 hojas
correderas



E4FA



Angular 2 hojas fijas 2 hojas
correderas



F4A



Angular ducha 2 hojas fijas y 2 hojas abatibles 90°



G4FA



Frontal ducha 2 hojas abatibles 180° y
2 hojas fijas

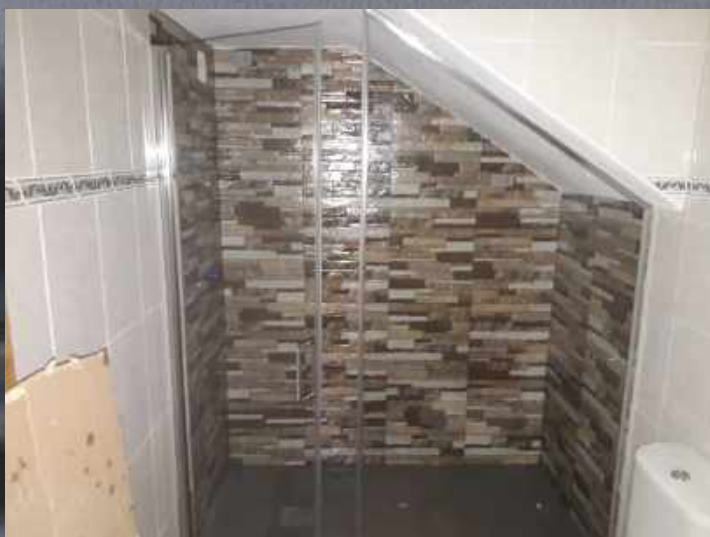



calidad superior

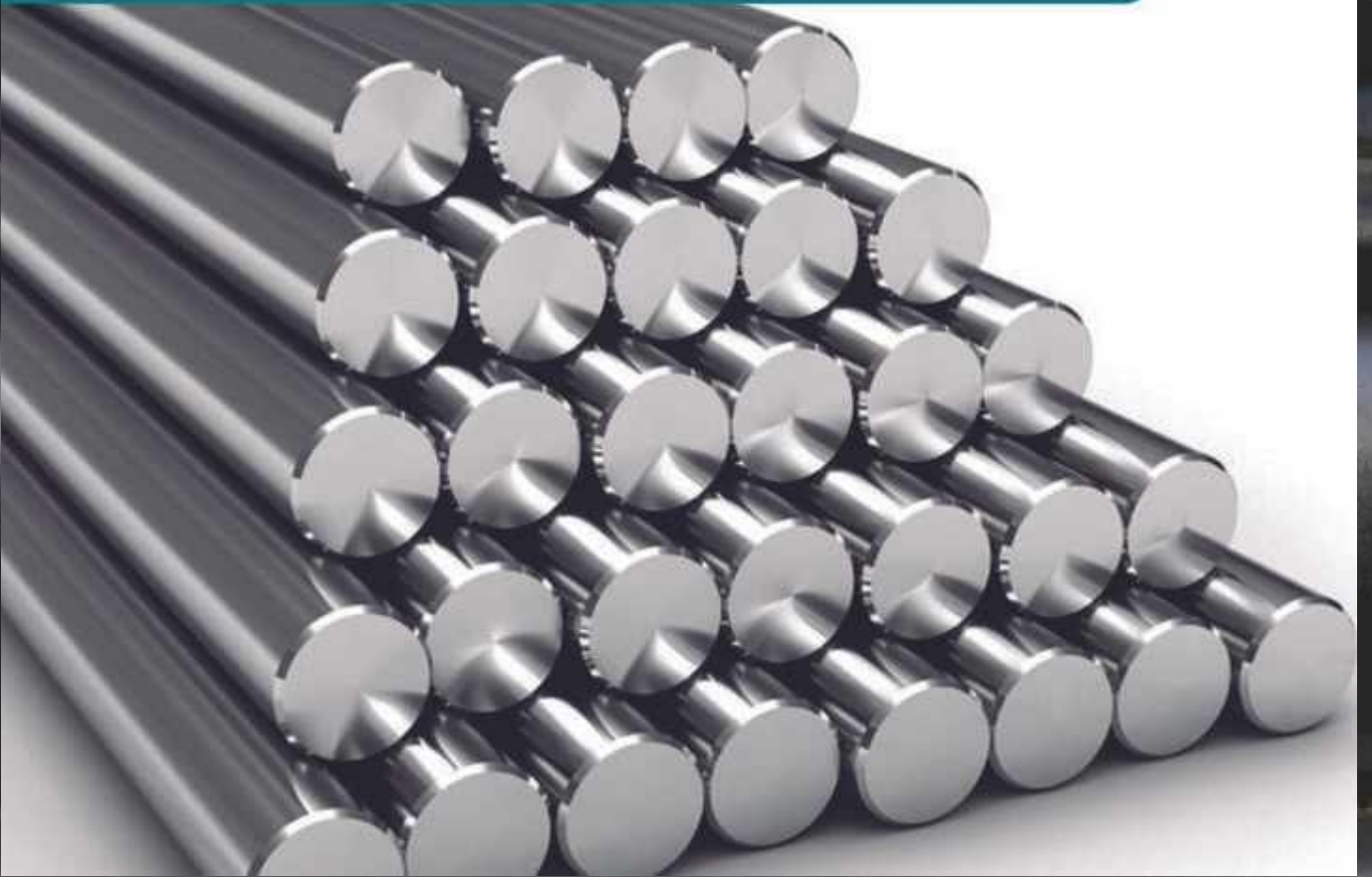

XXXXXXXXXX

· CALIDAD ·

SIGNIFICA HACER LO CORRECTO CUANDO NADIE

ESTÁ MIRANDO

-Henry Ford

MUEBLES DE BAÑO.

"NUESTRA EXTENSA GAMA DE MUEBLES ESTA FABRICADA PARA DUTXALIUM POR PRESTIGIOSO FABRICANTE PIONERO EN DISEÑO DE MUEBLES DE BAÑOS, CON UNA DILATADA EXPERIENCIA DE MÁS DE 35 AÑOS EN EL SECTOR, POSEE UNO DE LOS SISTEMAS MAS AVANZADO EN PRODUCCIÓN Y GESTIÓN, Y UN DEPARTAMENTO I+D EN CONSTANTE DESARROLLO PARA ESTAR A LA CABEZA EN INNOVACIÓN.

CON UNAS INSTALACIONES DE MÁS DE 55000 METROS CUADRADOS DISPONIBLES QUE LE PERMITEN AFRONTAR CUALQUIER PROYECTO A NIVEL NACIONAL COMO INTERNACIONAL.



DISEÑOS ACTUALES, LAS ULTIMAS TENDENCIAS Y TECNOLOGÍAS APLICADAS SIEMPRE CON LA MEJOR RELACIÓN CALIDAD/PRECIO DEL MERCADO.

ESTA COALICIÓN NOS PERMITE OFRECER A NUESTROS CLIENTES CUALQUIER MUEBLE QUE EXIJA SU PROYECTO. DIGANOS QUE NECESITA, DEL RESTO NOS OCUPAMOS NOSOTROS..."



"La simplicidad llevada al extremo, se convierte en elegancia."
-John Franklin





Melamina 16 mm.

			
Nature	Nebraska	Ceniza	Blanco seda

Melamina 19 mm.

					
Creta Claro	Creta oscuro	Iobaco	Nato	Antracita	Sepia

Acabados Laca seda / Microtec

				
Fango	Verde claro	Oliva	Negro	Hormigon

* Laca Seda Incremento 15 %



GAMA / 1

Mueble cajón uñero
 Cajón extracción total, cierre amortiguado
 Acabado melamina de 16 mm. o de 19 mm.
 Opción lacado en colores seda mate
 Top melamina o microtec
 Lavabo cerámico blanco o colores microtec

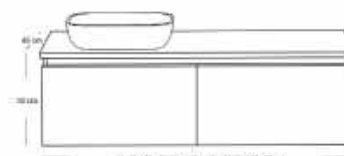



Melamina 16 mm.



Melamina 19 mm.



Acabados Laca seda / Microtec



* Laca Seda Incremento 15 %



GAMA / 1 / DOBLE

Mueble 2 cajones uñero
 Cajón extracción total, cierre amortiguado
 Acabado melamina de 16 mm. o de 19 mm.
 Opción lacado en colores seda mate
 Top melamina o microtec
 Lavabo cerámico blanco o colores microtec

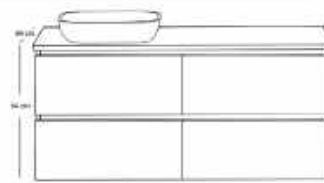

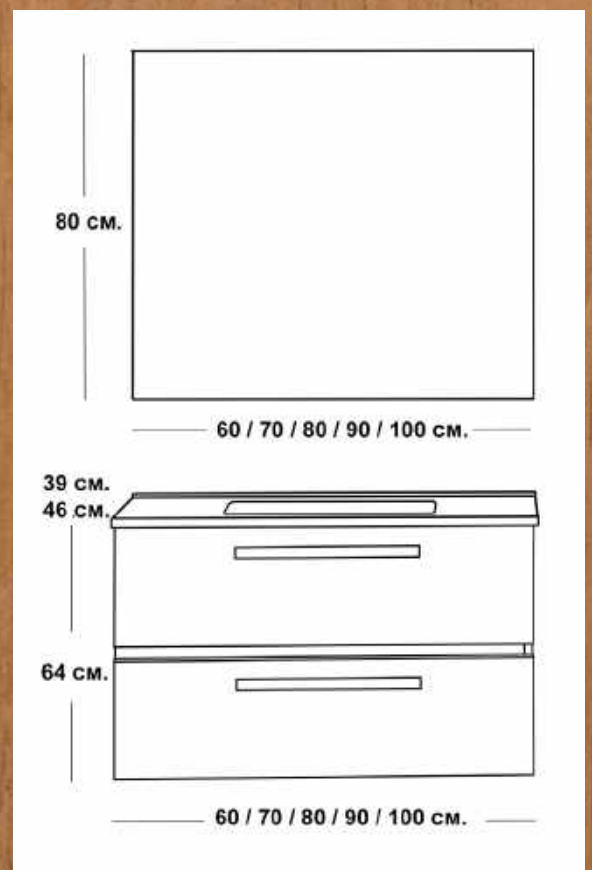

GAMA / 2

Mueble 2 cajones, con tirador o uñero
Cajón cierre amortiguado, interior textil
Acabado melamina de 16 mm.
Lavabo cerámico blanco

CONJUNTO:
* Mueble
* Lavabo cerámico
* Espejo luna lisa

Melamina 16 mm.



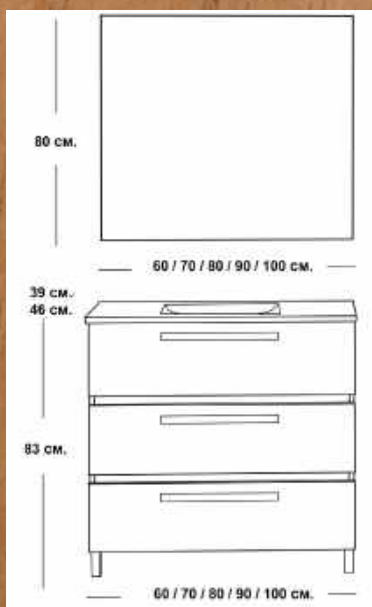

GAMA / 3

Mueble 3 cajones con tirador o uñero
Cajón cierre amortiguado, interior textil
Acabado melamina de 16 mm.

CONJUNTO:
* Mueble
* Lavabo cerámico
* Espejo luna lisa

Melamina 16 mm.



Nature



Nebraska



Blanco seda

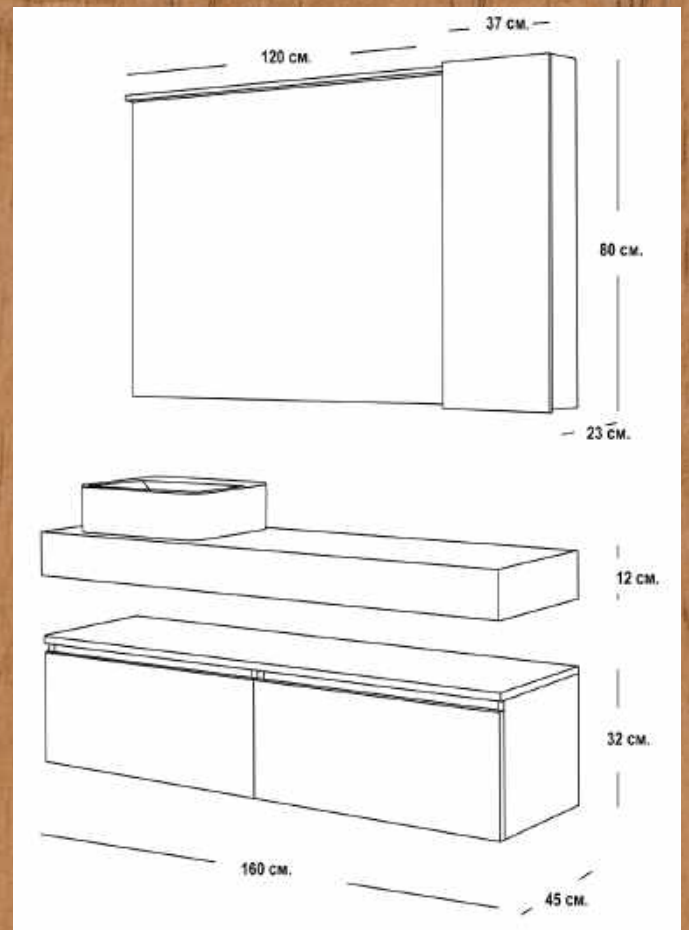

Melamina 16 mm.



Nature



Nebraska



Ceniza



Blanco seda

Melamina 19 mm.



Creta Claro



Creta oscuro



Tobaco



Nato



Antracita



Sepia



GAMA / 4

- Encimera ingletada a medida
- Módulo cajón + top madera
- Cajón extracción total cierre amortiguado
- Espejo con aplique barra led
- Lavabos cerámico blanco o colores Microtec
- Tops acabados de 16 - 19 mm. o laca seda
- Módulo acabados de 16 - 19 mm. o laca seda



Melamina 16 mm.



Melamina 19 mm.



Acabados Laca seda / Microtec



* Laca Seda
Incremento 15 %

GAMA / 5

Mueble 2 cajones, uñero + top madera
Cajón metálico, extracción total con cierre amortiguado
Acabado melamina de 16 - 19 mm.
Lavabo cerámico blanco o color

* Posibilidad encimera cerámica completa

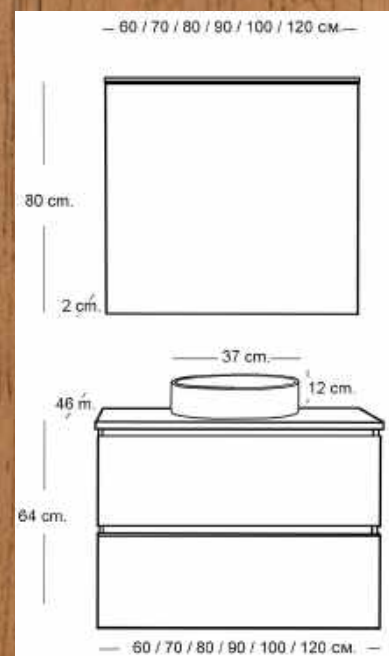

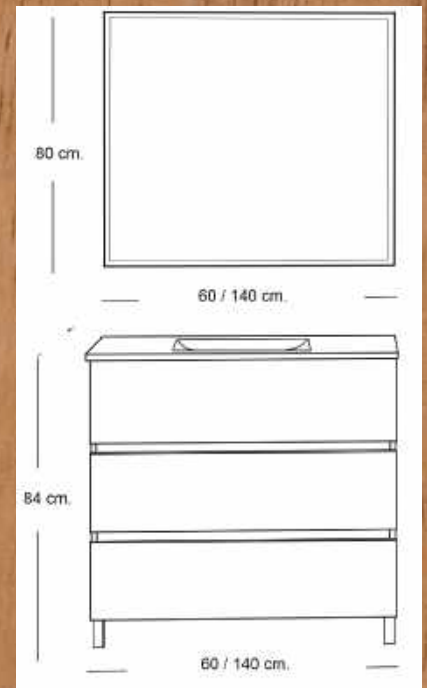

Melamina 16 mm.



Melamina 19 mm.



Acabados Laca seda / Microtec



* Laca Seda
Incremento 15 %



GAMA / 5 / 3 Cajones

Mueble 3 cajones, uñero + encimera porcelana
Cajones metálico, extracción total con cierre amortiguado
Acabado melamina de 16 - 19 mm.
Lavabo encimera blanco

GAMA 6

ACABADOS Melamina 16 mm.



Nature



Nebraska



Blanco seda



Mueble 2 cajones, lavabo porcelana

Melamina 16 mm.

Uñero o Tirador

Guía oculta

83 cm.

39 cm.

46 cm.

60 / 70 / 80 / 90 / 100 cm.

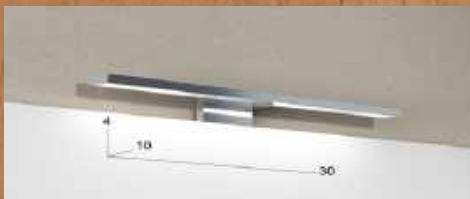

Espejo luna lisa,
cantos pulidos

80 cm.

2 cm.

80 / 90 / 100 / 120 cm.

Mueble 3 cajones, lavabo porcelana

Melamina 16 mm.

Uñero o Tirador

Guía oculta

83 cm.

39 cm.

46 cm.

60 / 70 / 80 / 90 / 100 cm.



GAMA 7

ACABADOS Melamina 16 mm.



Nature



Nebraska



Blanco seda

Acabados Laca seda / Microtec



Fango



Verde claro



Oliva



Negro



Hormigón

* Laca Seda
Incremento 15 %



Mueble 2 cajones, lavabo porcelana

55 cm.

39 cm.

48 cm.

60 / 70 / 80 / 90 / 100 / 120 cm.

Melamina 16 mm.

Uñero o Tirador

Guía oculta



Mueble 2 cajones, lavabo porcelana

55 cm.

39 cm.

48 cm.

120 cm.

Melamina 16 mm.

Uñero o Tirador

Guía oculta



Columna auxiliar 2 puertas

Melamina 16 mm.

Uñero o Tirador

GAMA 8

ACABADOS Melamina 16 mm.



Nature



Nebraska



Blanco seda

Acabados Laca seda / Microtec



Fango



Verde claro



Oliva



Negro



Hormigón

* Laca Seda
Incremento 15 %

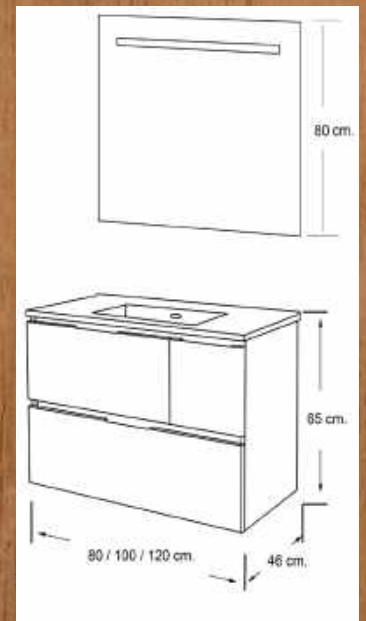

Mueble 3 cajones uñero
Cajón metálico extracción total, cierre amortiguado
Acabado melamina de 16 mm.
Opción lacado en colores seda mate
Lavabo cerámico blanco
Espejo led horizontal

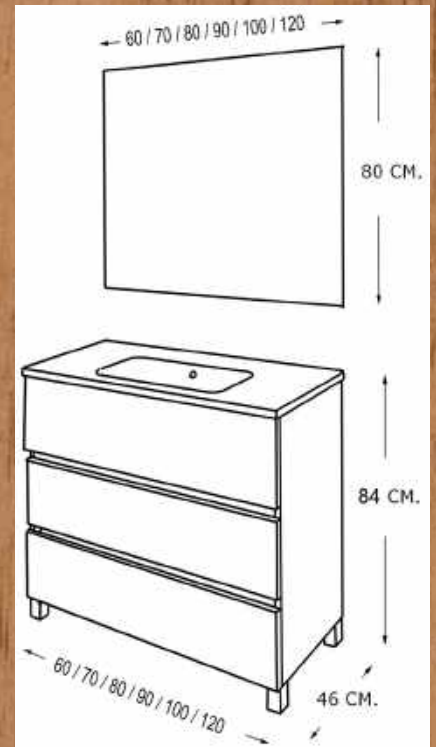

GAMA / 9

Mueble 3 cajones uñero
 Tirador barra uñero
 Cajón cierre amortiguado interior textil
 Acabado melamina de 16 mm.
 Opción lacado en colores seda mate
 Lavabo cerámico blanco

CONJUNTO:
 * Mueble
 * Lavabo cerámico
 * Espejo luna lisa

Melamina 16 mm.

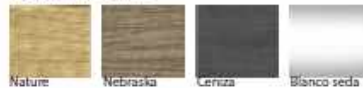

Acabados Laca seda / Microtec



* Laca Seda
 Incremento 15 %

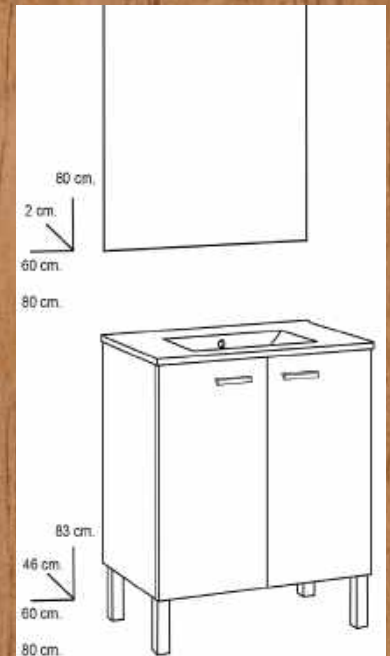

- CONJUNTO:**
- * Mueble
 - * Lavabo cerámico
 - * Espejo luna lisa



GAMA / 10

Mueble 2 Puertas con tirador
 Opción lacado en colores seda mate
 Lavabo cerámico blanco
 Acabado melamina 16 mm.

Melamina 16 mm.



Acabados Laca seda / Microtec





Melamina 18 mm.



Nature Nebraska Leniza Blanco seda

Acabados Laca seda / Microtec



Tango Verde claro Oliva Negro Hormigon

* Laca Seda
Incremento 15 %

GAMA / 11

Mueble 2 Puertas con tirador
Puertas autocierre suave,
Opción lacado en colores seda mate
Lavabo cerámico blanco
Acabado melamina 16 mm.





GAMA / 12

Mueble 1 puerta con tirador
 Puerta autocierre suave,
 Lacado en colores seda mate
 Lavabo cerámico blanco
 Acabado melamina 16 mm.

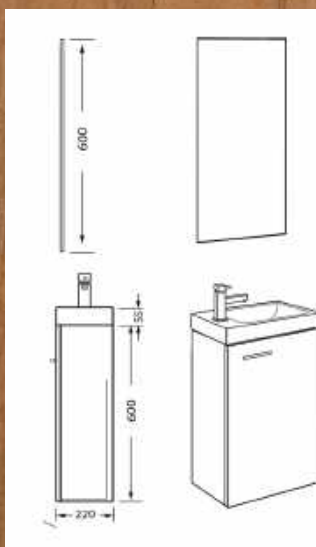



GAMA / 13

Mueble Puerta y cajón uñero
 Puerta y cajón autocierre suave,
 Lacado en colores seda mate microtec
 Lavabo cerámico blanco
 Acabado lacado 16 mm.

CONJUNTO:

- * Mueble
- * Lavabo cerámico
- * Top



Acabados Laca seda / Microtec



Fango

Verde claro

Oliva

Negro

Hormigón

Blanco seda

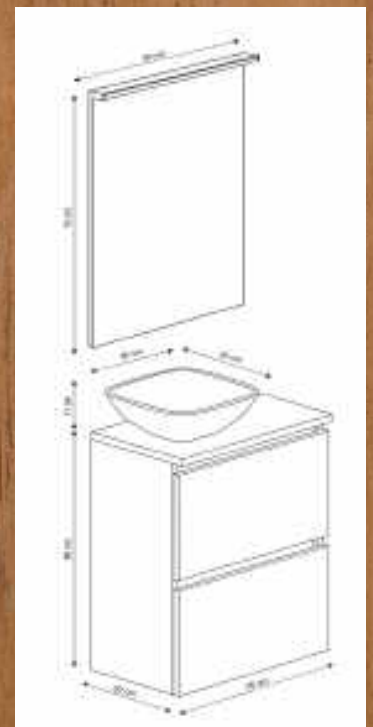



GAMA / 14

Columna y armarios
Puerta autocierre suave,
Acabado melamina 16 mm.

Melamina 16 mm.





Cajón con sistema de extracción total.

Drawers with total extraction system.



landes.

60 / 70 / 80 / 100 / 120





Cajón con sistema de extracción total.

Drawers with total extraction system.

sigma.







80 / 100 / 120 / 140





omega.

60 / 80 / 100 / 120

- | | | | |
|--|---|---|-----------------|
|  |  |  | brillo / glossy |
|  |  |  | mate / matte |



Cajón con sistema de extracción total.

Drawers with total extraction system.





berlín.

60 / 70 / 80 / 100



Cajón con sistema de extracción total.

Drawers with total extraction system.



lúxor.

80 / 100

○ ● ● ●



Cajón con sistema de extracción total.
Drawers with total extraction system.



Cajón con sistema de extracción total.
Drawers with total extraction system.

toscana.

60 / 80 / 100





flow.
60 / 70 / 80 / 100 / 120 / 140
● ●





ambar lip.
70 / 80 / 100 / 120
solid surface





epsilon.

60 / 80 / 100 / 120

Carga mineral de resina recubierta con poliuretano acrílico en 20 colores.

Superficie con tratamiento antibacterias.

Fácil limpieza, se pueden limpiar con casi todos los productos de limpieza habitual.



oslo.

70 / 80 / 100 / 120







brillo glossy mate mate





Cajón con sistema de extracción total.
 Drawers with total extraction system.



praga.

60 / 70 / 80 / 100 / 120



Cajón con sistema de extracción total.

Drawers with total extraction system.





galsaky.

60 / 70 / 80 / 100



Cajón con sistema de extracción total.

Drawers with total extraction system.



galsaky.
INDUSTRIAL

60 / 70 / 80 / 100 / 120

○ ● ● ● ●



Cajón con sistema de extracción total.

Drawers with total extraction system.



escorpio.

60 / 70 / 80 / 100



Cajón con sistema de extracción total.
 Drawers with total extraction system.



Cajón con sistema de extracción total.

Drawers with total extraction system.





comet. fondo reducido

60 / 70 / 80

○ ●



 **Cajón con sistema de extracción total.**
Drawers with total extraction system.



berna. fondo reducido

50 / 60



Cajón con sistema de extracción total.

Drawers with total extraction system.



siena. fondo reducido
70 / 80

○ ●



 **Cajón con sistema de extracción total.**
Drawers with total extraction system.



versa. fondo reducido

45 / 55





ENCIMERAS ESPECIALES



"PARA DUTXALIUM EL BAÑO ES UN ESPACIO DE DISEÑO QUE AÚNA FUNCIONALIDAD Y ESTÉTICA, UNO DE LOS ESPACIOS MÁS INSPIRADORES EN LA ARQUITECTURA CONTEMPORÁNEA.

ENTENDEMOS EL BAÑO COMO UN ENTORNO HABITABLE EN EL QUE EL CONCEPTO ARQUITECTÓNICO SE DECLINA EN COMODIDAD, CALIDAD Y DISEÑO. Y PARA ELLO CONTAMOS CON DIFERENTES LÍNEAS DE PRODUCTOS QUE PERMITEN CREAR UN BAÑO EFICIENTE, A MEDIDA, CON UNA ESTÉTICA UNIFICADA, AGRADABLE Y COHERENTE.

ESTA VISIÓN DEL BAÑO COMO UN ESPACIO EXPERIENCIAL SUJETO A LOS PRINCIPIOS DEL DISEÑO Y LA FUNCIONALIDAD, NOS EMPUJA A BUSCAR CONSTANTEMENTE SERVIR A NUESTROS CLIENTES CON PRODUCTOS ACORDES A LA ADAPTACIÓN DE TENDENCIAS ARQUITECTÓNICAS A LOS NUEVOS ESTILOS DE VIDA DE QUIENES HABITAN LOS ESPACIOS."

EXISTEN TRES RESPUESTAS POSIBLES ANTE UN DISEÑO: SI, NO y WOW!

HAY QUE ASPIRAR A

Milton Glaser

WOW!



MIR

encimera especial

encimera especial **MIR**
Cada 10 cm. de ancho vale 10 cm.

MIR encimera plana **MIR encimera tallada**

100 cm x 49 y 68 100 cm x 49 y 68

Modelo encimera plana en cm

Modelo encimera tallada en cm

Incremento **PIZA DESPLAZADA** Incremento **DOBLE PIZA** Incremento **COFETE** Múltiple Cofete

Incremento **TALLADO INTERIOR** (1.00 cm x 2.00 cm) Incremento **REPORTES VERTIC** (1.00 cm x 2.00 cm) Incremento **REPORTES DOBLE TALL** (1.00 cm x 2.00 cm)

Incrementos:

- Incremento de ancho: 10 cm
- Incremento de altura: 10 cm
- Incremento de profundidad: 10 cm
- Incremento de anchura: 10 cm
- Incremento de altura: 10 cm
- Incremento de profundidad: 10 cm

Acabados Standard

Blanco	Crema	Beige	Verde
Ref. 001	Ref. 002	Ref. 003	Ref. 004
Grigio	Negro	Marrón	Rojo
Ref. 005	Ref. 006	Ref. 007	Ref. 008

Acabados Carta **RAL**

Incremento de ancho: 10 cm de ancho vale 10 cm de ancho. Incremento de altura: 10 cm de altura vale 10 cm de altura.





KUO

encimera especial



encimera especial **KUO**
línea de encimeras especiales

KUO encimera plana **KUO** encimera decañon

49 66

49 66

Incremento PUGA DEBIL AZUL

Incremento DEBIL PUGA

Incremento COFRE

Incremento TALLERES BIFORADO

Incremento BIFORADO VISTOS

Incremento BIFORADO COLETE

Incrementos

Acabados Standard

Acabados Carta **RAL**

REM

encimera especial



encimera especial

REM

REM encimera diana 1500

REM encimera skin 1500

38

Perforación PC61 DESP. 220x200
 Perforación D60x14 PC62
 Perforación D60x14 PC63
 Perforación D60x14 PC64
 Perforación D60x14 PC65
 Perforación D60x14 PC66
 Perforación D60x14 PC67
 Perforación D60x14 PC68
 Perforación D60x14 PC69
 Perforación D60x14 PC70
 Perforación D60x14 PC71
 Perforación D60x14 PC72
 Perforación D60x14 PC73
 Perforación D60x14 PC74
 Perforación D60x14 PC75
 Perforación D60x14 PC76
 Perforación D60x14 PC77
 Perforación D60x14 PC78
 Perforación D60x14 PC79
 Perforación D60x14 PC80

Acabados Standard

Acabados Carta

REAL

NEO

encimera especial



encimera especial **NEO**

NEO para KUO 28
ancho 49 y 60

NEO para MIR 26
ancho 40 y 65

NEO para REM 380

49 60 40 65 380

49 60 40 65 380

Equipamiento: PISA A DESPLAZADA

Incremento: DOBLE PISA

Incremento: COPETE

Incremento: TALLERES INTEGRADOS

Incremento: SOPORTES VITROS

Incremento: SOPORTES CALZADO

Incrementos

Acabados Standard

Acabados Clari

RAL

LAVABOS SOBRE ENCIMERAS



JANA



LUZ

Acabados Standard

Blanco Ref. 0000	Grigio Ref. 1142
Crema Ref. 0001	Antico Ref. 1118
Beige Ref. 0101	Chocola Ref. 1017
Verde Ref. 0102	Negro Ref. 0002

Acabados Carta **RAL**

Incrementos:
 *Ficha técnica 2004/PF Incremento PPF en colorido de cerámicas.
 *Ficha técnica 2004/PF Incremento PPF en colorido de cerámicas.
 *Ficha técnica 2004/PF Incremento PPF en colorido de cerámicas.
 *Ficha técnica 2004/PF Incremento PPF en colorido de cerámicas.
 *Ficha técnica 2004/PF Incremento PPF en colorido de cerámicas.
 *Ficha técnica 2004/PF Incremento PPF en colorido de cerámicas.
 *Ficha técnica 2004/PF Incremento PPF en colorido de cerámicas.

Acabados Standard

Blanco Ref. 0000	Grigio Ref. 1142
Crema Ref. 0001	Antico Ref. 1118
Beige Ref. 0101	Chocola Ref. 1017
Verde Ref. 0102	Negro Ref. 0002

Acabados Carta **RAL**

Incrementos:
 *Ficha técnica 2004/PF Incremento PPF en colorido de cerámicas.
 *Ficha técnica 2004/PF Incremento PPF en colorido de cerámicas.
 *Ficha técnica 2004/PF Incremento PPF en colorido de cerámicas.
 *Ficha técnica 2004/PF Incremento PPF en colorido de cerámicas.
 *Ficha técnica 2004/PF Incremento PPF en colorido de cerámicas.
 *Ficha técnica 2004/PF Incremento PPF en colorido de cerámicas.
 *Ficha técnica 2004/PF Incremento PPF en colorido de cerámicas.



KIRA

Acabados Standard

Blanco Ref. 0000	Grigio Ref. 1142
Crema Ref. 0001	Antico Ref. 1118
Beige Ref. 0101	Chocola Ref. 1017
Verde Ref. 0102	Negro Ref. 0002

Acabados Carta **RAL**

Incrementos:
 *Ficha técnica 2004/PF Incremento PPF en colorido de cerámicas.
 *Ficha técnica 2004/PF Incremento PPF en colorido de cerámicas.
 *Ficha técnica 2004/PF Incremento PPF en colorido de cerámicas.
 *Ficha técnica 2004/PF Incremento PPF en colorido de cerámicas.
 *Ficha técnica 2004/PF Incremento PPF en colorido de cerámicas.
 *Ficha técnica 2004/PF Incremento PPF en colorido de cerámicas.
 *Ficha técnica 2004/PF Incremento PPF en colorido de cerámicas.



ENCIMERA
FALDÓN

TEXTURA: Lisa / Pizarra
ACABADO: Mate / Brillo



ENCIMERA
PLANA

TEXTURA: Lisa / Pizarra
ACABADO: Mate / Brillo

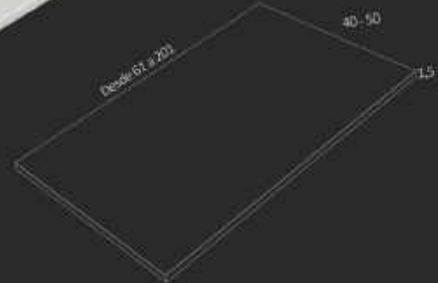
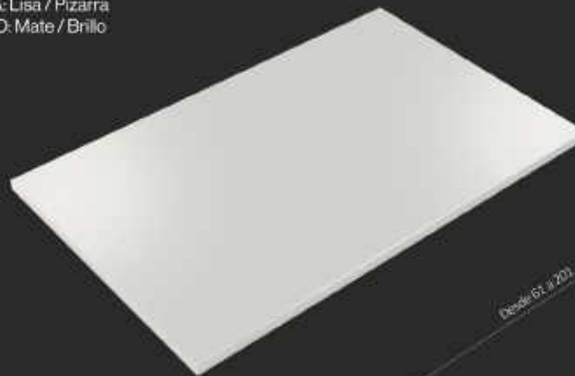

Certificado de Calidad y Ensayos

Plato Ducha

REVESTIMIENTO DE PLATO DE DUCHA CARGA MEDIA.
ACABADO EN SE, EGAT

RESISTENCIA AL DESGASTO UNO (UNE 9303.200)
ENSAYO EN KUMHO

Fecha del informe: 01

REVESTIMIENTO PLATO DUCHA	REFERENCIA ACABADO
SEÑALACION	TRANSVERSAL
Identificación prueba	1 2 3 4 5 1 2 3 4 5
SEÑALACION	SEÑALACION
Valor medio por prueba	85 85 41 85 85 85 41 85 85

REVESTIMIENTO PLATO DUCHA

REFERENCIA ACABADO

48

CLASE DE GENERALIZACION*

12.482 0

*) Por analogía y considerando el Índice Técnico de Edificios - CTE - Edificio de uso público, en sus arts. 19 de mayo de 2011 y modificación conforme a la Ley 8/2013, de 26 de junio, de modificación legislativa y normativa técnica, así como en su artículo 1 según la resistencia al deslizamiento, de acuerdo con la norma UNE EN 1082.503 y modificación de prueba de prueba.

Laboratorio de Edificios Página 11 de 11

Lavabo Encimera

5. RESULTADOS OBTENIDOS

LAVABO CARGA MEDIANA, ACABADO EN TOP COAT ALUMINIO

ENSAYOS REALIZADOS	MÉTODOS	RESULTADOS
Resistencia a la carga (estática)	UNE 10820 Aplicado 5.0	No rotura
Resistencia al agua (estática)	UNE 10820 Aplicado 5.0	Completos
Resistencia a la corrosión (ácido)	UNE 10820 Aplicado 5.0	Sin roturas Completos
Resistencia a la abrasión (estática y dinámica - 1000 ciclos)	UNE 10820 Aplicado 5.0	Sin roturas Completos
Resistencia de la superficie. Rayado (según UNE 10820.503) (línea). Prueba realizada en la línea (línea)	UNE 10820 Aplicado 5.0	1.25 Sin roturas Completos
Resistencia de la superficie. Rayado (según UNE 10820.503) (área). Prueba realizada en la línea (línea)	UNE 10820 Aplicado 5.0	Sin roturas Completos
Resistencia de la superficie. Rayado (según UNE 10820.503) (área). Prueba realizada en la línea (línea)	UNE 10820 Aplicado 5.0	Completos
Resistencia de la superficie. Rayado (según UNE 10820.503) (área). Prueba realizada en la línea (línea)	UNE 10820 Aplicado 5.0	1.11 Sin roturas

Resistencia:

UNE 10820
Aplicado 5.0

Completos

*) El valor obtenido en el ensayo se refiere al número de ciclos realizados por la muestra.

La muestra presentada cumple los requisitos contemplados en la norma UNE EN 1082.503. Para mayor información, favor de contactar al Laboratorio de Edificios y al departamento correspondiente a

EN 1082.503

Laboratorio de Edificios Página 9 de 11



stone.compact

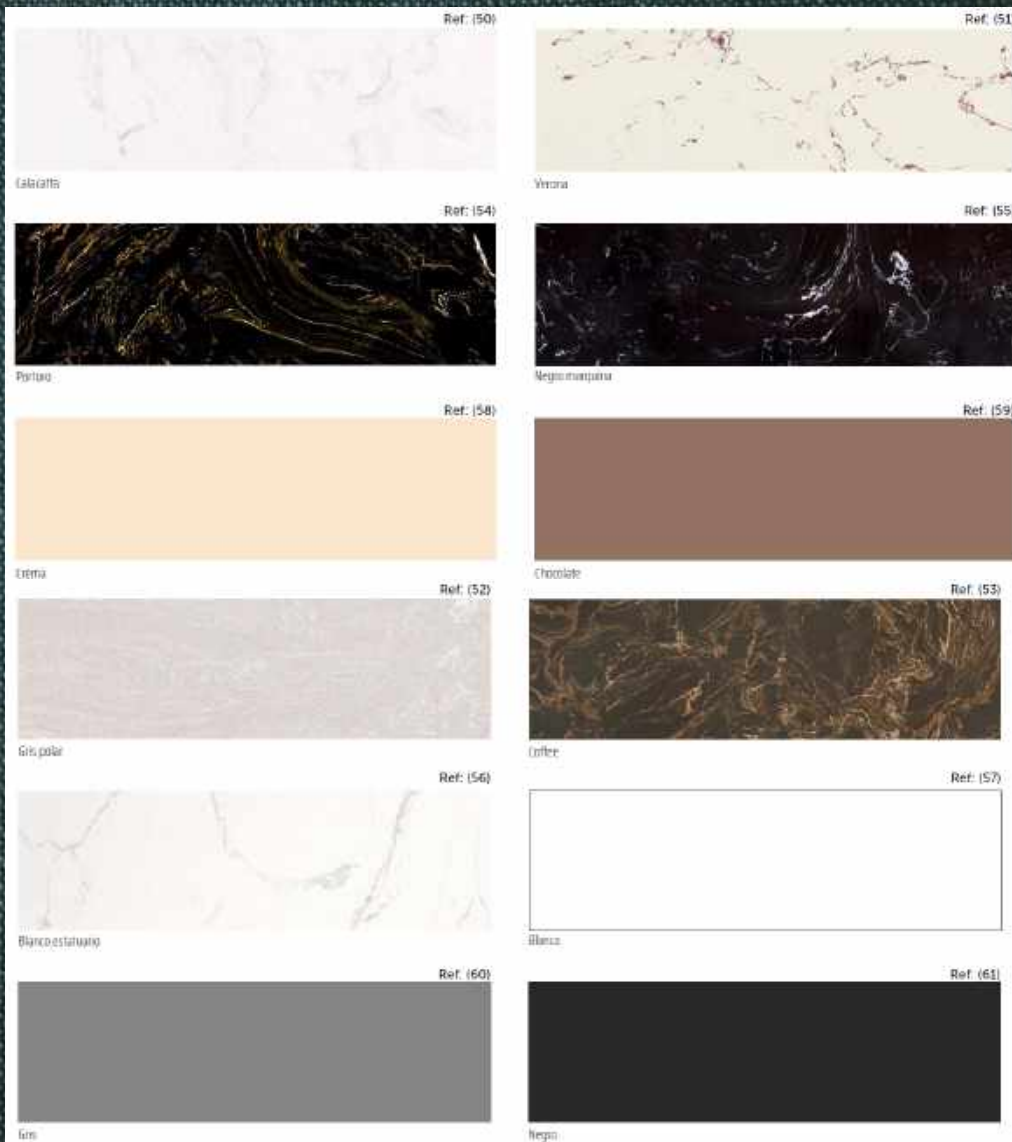



stoneplus.

					
50 Calacatta	51 Verona	52 Gris polar	53 Coffee	54 Portoro	55 Negro marquina
					
56 Blanco estatuario	57 Blanco	58 Crema	59 Chocolate	60 Gris	61 Negro





átika.



50 Calacatta



51 Verona



52 Gris polar



53 Coffee



54 Portoro



55 Negro marquina



56 Blanco estatuario



57 Blanco



58 Crema



59 Chocolate



60 Gris



61 Negro



perse.



- | | | | | | |
|---|---|---|---|---|---|
|  |  |  |  |  |  |
| 50 Calacatta | 51 Verona | 52 Gris polar | 53 Coffee | 54 Portoro | 55 Negro marquina |
|  |  |  |  |  |  |
| 56 Blanco estatuario | 57 Blanco | 58 Crema | 59 Chocolate | 60 Gris | 61 Negro |





petra.

					
50 Calacatta	51 Verona	52 Gris polar	53 Coffee	54 Portoro	55 Negro marquina
					
56 Blanco estatuario	57 Blanco	58 Crema	59 Chocolate	60 Gris	61 Negro











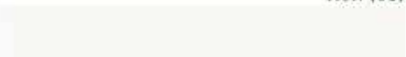

umma.

					
50 Calacatta	51 Verona	52 Gris polar	53 Coffee	54 Portoro	55 Negro marquina
					
56 Blanco estatuario	57 Blanco	58 Crema	59 Chocolate	60 Gris	61 Negro





stone.tec

 Ref: (65)	 Ref: (64)	 Ref: (70)
Blanco mate	Negro mate	Verde oliva mate
 Ref: (69)	 Ref: (63)	 Ref: (66)
Hormigón mate	Azul índico	Capuchino mate
 Ref: (62)	 Ref: (67)	 Ref: (68)
Azul mate	Verde claro mate	Fango mate



LAVABOS Y SANITARIOS.

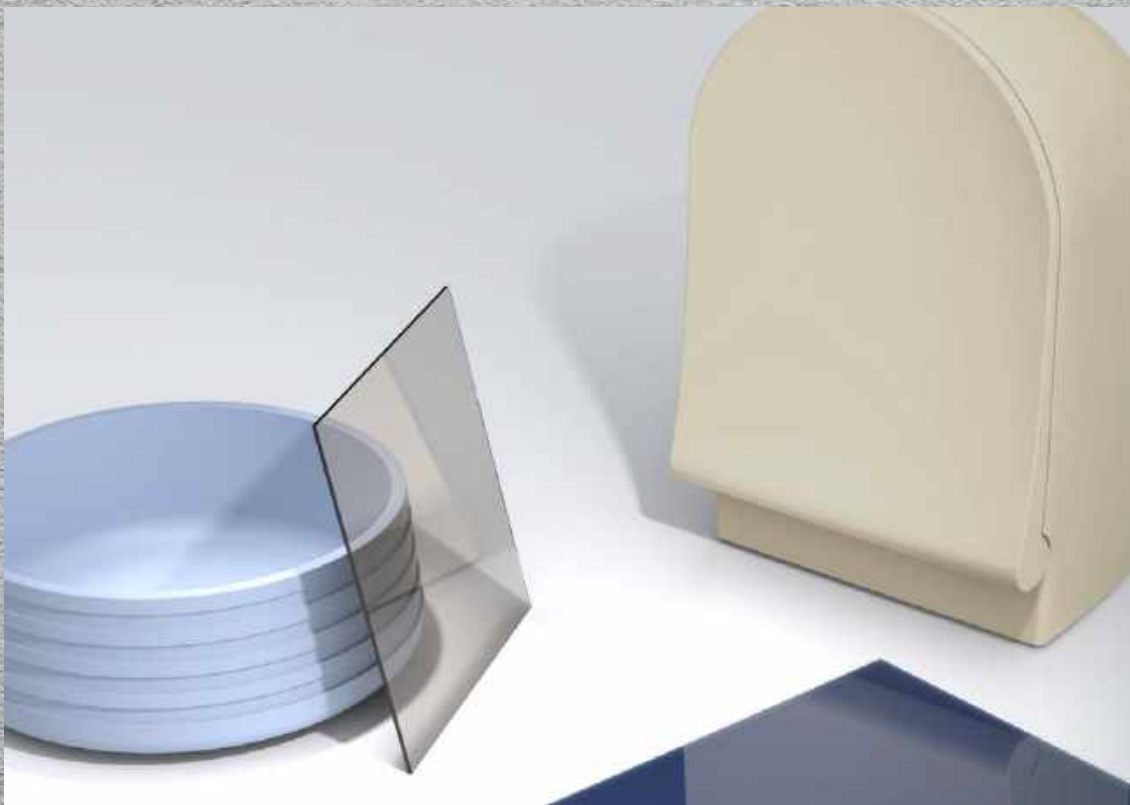

DISEÑO ICÓNICO.

Una serie funcional que permite la armonía y el diseño integrado entre los elementos del baño.

Sobre todo gracias a la variedad de formas y diseños. Sin dejar de lado las importantes características de comodidad y practicidad.

Todos los productos son de una cuidada estética, con líneas suaves y aportando una gran sensación de ligereza

COMODIDAD Y FUNCIONALIDAD.

Los inodoros suspendidos son uno de esos elementos que conjugan a la perfección el diseño, la comodidad y la funcionalidad.

Su diseño ofrece un espacio de baño libre de obstáculos y, al mismo tiempo, es un elemento moderno importante.

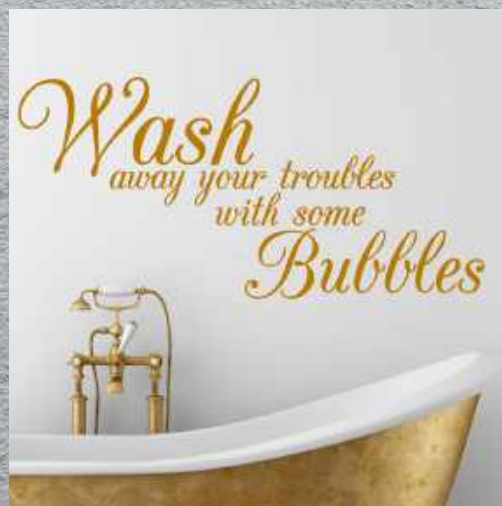

COLOURS BASINS



MINERAL BASINS



STONE BASINS



DESIGN BASINS



WALL-HUNG SANITARYWARE



CLOSE-COUPLE SANITARYWARE



WC COLOURS COLLECTION



FREESTANDING BATHTUBS



GRIFERIAS Y DUCHAS.



"SERÍA UN ERROR CREER QUE NO HAY MUCHO QUE PENSAR A LA HORA DE DISEÑAR O PLANEAR UNA NUEVA DUCHA PARA LA REFORMA DE TU BAÑO. Y ES QUE INCLUSO LOS DISEÑOS MÁS MINIMALISTAS DE DUCHAS REQUIEREN UNA CONSIDERACIÓN CUIDADOSA Y EN REALIDAD SON MÁS COMPLEJOS DE LO QUE PARECEN. LAS DECISIONES DEBEN TOMARSE CON RESPECTO A TODO TIPO DE DETALLES, COMO EL TIPO DE MATERIALES UTILIZADOS, LA PALETA DE COLORES, INCLUSO EL DISEÑO Y UBICACIÓN ACTUALES. ¿TE ATREVES A IMAGINAR CON NOSOTROS TU NUEVA DUCHA?"

LAS GRIFERÍAS PARA BAÑO IMEX AÚNAN UN DISEÑO GALARDONADO CON LOS MEJORES MATERIALES Y LO ÚLTIMO EN TECNOLOGÍA. CADA COLECCIÓN OFRECE UNA GRAN VARIEDAD DE MODELOS PARA CUMPLIMENTAR CON TODO TIPO DE ESTILOS DE BAÑO Y PREFERENCIAS DE LOS USUARIOS.

TODOS NUESTROS ARTICULOS SON DE FABRICACIÓN NACIONAL CON GARANTIA EXCEPCIONAL DE 5 AÑOS. (*LOS MODELOS ILUSTRADOS SON A MODO DE EJEMPLO,, HAY UN CATALOGO GENERAL CON UNA EXTENSA GAMA A DISPOSICIÓN DEL CLIENTE.)

**"En medio de la dificultad,
yace la oportunidad."**

Albert Einstein

ROMA

SERIE

Modelo polivalente y adaptable a cualquier baño. Robustez y sobriedad son sus principales cualidades.



Modelo polivalente y adaptable a cualquier baño. Robustez y sobriedad son sus principales cualidades.



Ref.: BDR002

Serie de ducha y sistema de agua fría, negro mate, adaptable a 1/2" y 3/4".
 Regulador de caudal: máx. 60 l/min, 100 l/min, 120 l/min y 150 l/min.
 Mango de ducha: 20 x 20 x 10 cm.
 Caudal de ducha: negro mate.
 Medidas: 100 x 100 x 100 cm.
 Caudal máx.: 120 l/min.
 Dimensiones: 100 x 100 x 100 cm.
 Serie: FNC, negro mate, 1/2".
 Caudal máx.: 120 l/min.

Ref.: BDR002-1

Módulo de ducha.
 Caudal de ducha: 120 l/min.
 Caudal de ducha: negro mate.
 Medidas: 100 x 100 x 100 cm.

Ref.: BDR002-2

Módulo de ducha.
 Caudal de ducha: 120 l/min.
 Caudal de ducha: negro mate.
 Medidas: 100 x 100 x 100 cm.





LUXOR
NEGRO MATE
SERIE

LUXOR
BLANCO MATE
SERIE



LUXOR
SERIE



LUXOR
BLANCO MATE
SERIE

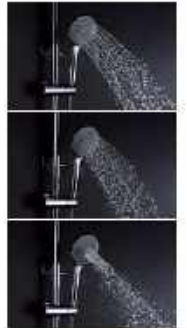

Modelos de líneas curvas y redondeadas que aportan al baño confort, elegancia y bienestar.



MILOS

SERIE

Modelos de líneas curvas y redondas que aportan al baño confort, elegancia y bienestar.



MILOS NEGRO MATE

SERIE



Modelos de líneas curvas y redondas que aportan al baño confort, elegancia y bienestar.

MILOS BLANCO MATE

SERIE

Modelos de líneas curvas y redondas que aportan al baño confort, elegancia y bienestar.



MILOS

SERIE



Modelos de líneas curvas y redondas que aportan al baño confort, elegancia y bienestar.



SUECIA

SERIE



Detalle de líneas rectas y acabados que proporcionan estilo y diseño en cualquier baño.

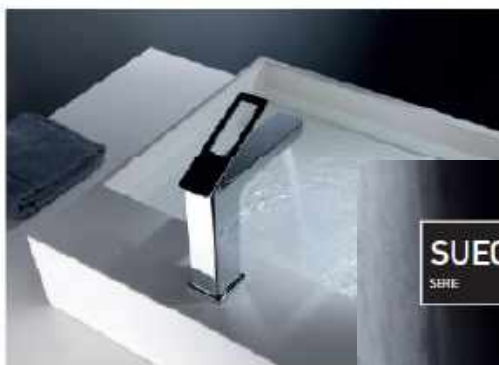

SUECIA

SERIE



SUECIA

SERIE



SUECIA NEGRO ORO ROSA

SERIE



DUCHA TERMOSTÁTICA DE
TECNOLOGÍA DE ÚLTIMA GENERACIÓN

IMEX
BATH EQUIPMENTS



RE-EVOLUCIÓN



**GRIFERÍA
TERMOSTÁTICA**

Griferías termostáticas de nueva generación con cartuchos cerámicos de polímero que les confieren una especial resistencia al agua de tipo medio y duro

38°C

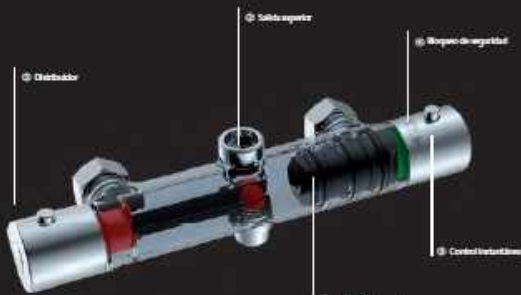

1. Con el cartucho hermetizado, asociado al flujo de agua y/o temperatura se pueden controlar de manera exacta y profesionalmente.

5. Control termostático de agua a temperatura adecuada en un instante, para evitar el desperdicio de la temperatura en la pared del agua que cambia, proporciónando una sensación constante y perfecta durante el baño.

2. Favorece la seguridad de los usuarios hermetizando la célula superior permitiendo controlar y evitar posibles fugas de agua fría y alta.

3. El bloque de seguridad evita un funcionamiento que obtiene una temperatura >38°C, para evitar quemaduras.

4. El distribuidor integrado permite seleccionar la salida del agua en una dirección o otra.





CRETA

SERIE



Nº. BTCD18

Manómetro de acero inoxidable Ø30 mm, con escala, controlador y anillo.
 Dimensiones mínimas de instalación 120 mm.
 Manguito de fibra, acabado: 2 pines Ø8 mm.
 Carrocería cromada con acabado satinado con resistencia al arañamiento.
 Resistencia máxima: 6 at. Anillo: 1.5 at.
 Caudal máximo: 12 l/min.
 Peso: 1,2 kg.
 Contacto: 100% latón y bronce.

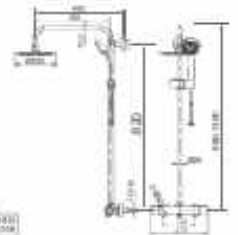

www.dufa.com

CRETA

SERIE

Nº. BTCD19-5

Manómetro de acero inoxidable Ø30 mm.
 Carrocería cromada con acabado satinado con resistencia al arañamiento.
 Sistema para montaje de ducha de 400 mm.
 Presión máxima: 6 at. Anillo: 1.5 at.
 Caudal máximo: 12 l/min.
 Peso: 1,2 kg.
 Contacto: 100% latón y bronce.



www.dufa.com

Cuerpo
frio



Cuerpo
frio



SIDNEY

SERIE

Ref.: BT5016

Reductor de acero inox., acabado 20x30 cm, cuadrado, cromado y antical.
 Bata de ducha integrada de 20,7x30 cm.
 Mango de fibra sintética.
 Cabezal horizontal de 20 cm con 200 orificios de distribución hexagonales.
 Paredes cromadas al níquel 2 µ.
 Caudal medio: 17 l/min.
 Clase PVC 1,5 m.
 Cálculo del patrimonio IMEX.

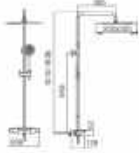

VIGO

SERIE



Ref.: BTV013

Reductor de acero inox. acabado 20x30 cm, cuadrado, cromado y antical.
 Bata de ducha integrada de 20,7x30 cm.
 Mango de fibra sintética.
 Cabezal horizontal de 20 cm con 200 orificios de distribución hexagonales.
 Paredes cromadas al níquel 2 µ.
 Caudal medio: 17 l/min.
 Clase PVC 1,5 m.
 Cálculo del patrimonio IMEX.

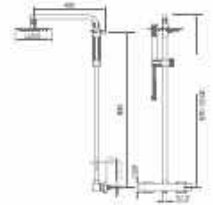

BLED

SERIE - Made in Europe

Uno de nuestros mejores productos. Durabilidad, resistencia y funcionamiento a muy baja presión hacen de este modelo uno de los más versátiles.

Ref.: BTB010

Reductor de acero inox. acabado 20x30 cm, cuadrado, cromado y antical.
 Bata de ducha integrada de 20,7x30 cm.
 Mango de fibra sintética.
 Cabezal horizontal de 20 cm con 200 orificios de distribución hexagonales.
 Paredes cromadas al níquel 2 µ.
 Caudal medio: 17 l/min.
 Clase PVC 1,5 m.
 Cálculo del patrimonio IMEX.



VIGO NEGRO MATE

SERIE



Ref.: BTV013NG

Reductor de acero inox. acabado 20x30 cm, cuadrado, negro mate y antical.
 Bata de ducha integrada de 20,7x30 cm.
 Mango de fibra sintética.
 Cabezal horizontal de 20 cm con 200 orificios de distribución hexagonales.
 Paredes cromadas al níquel 2 µ.
 Caudal medio: 17 l/min.
 Clase PVC 1,5 m.
 Cálculo del patrimonio IMEX.

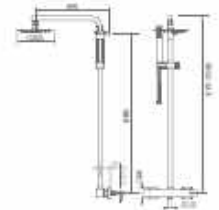

DUCHAS EMPOTRADAS



La máxima expresión del diseño y las últimas novedades del mercado nos conducen a la integración de los productos en el baño. IMEX se ha adaptado a los tiempos con la creación de diversas series empotradas.

ARUBA

SERIE

Lineas redondeadas y sutiles con un marcado carácter de diseño exclusivo y diferenciado.



Ref.: GPAR15

Detalle control.

Control.

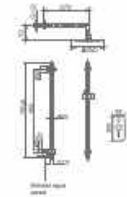

BAHAMAS NEGRO MATE

SERIE



Ref.: GPH16NG

Esta serie está en la más alta gama mate y ofrece un acabado con efecto espejo. Su diseño es moderno, elegante y práctico, con un ahorro de agua y energía. La línea horizontal es un detalle de esta serie. Capacidad: 12 litros. Tamaño: 150 mm. Instalación: 1/2".

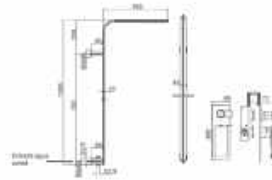

OSLO

SERIE



Detalle control.

Control.

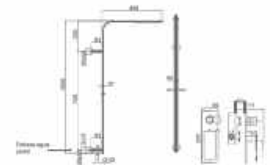

Lineas redondeadas y sutiles con un marcado carácter de diseño exclusivo y diferenciado.





SUMATRA

SERIE

Conjunto de ducha de nueva creación. Gracias a su espectacular rotador de grandes dimensiones y diseño, funciona capoteo de apertura y cierre empulsivo.



Rotador de gran tamaño, accionado por pulsador, con gran intensidad y efecto de lluvia. Incluye 2 tipos de rotación: 180° y 360°. Incluye un sistema de apertura y cierre empulsivo. Incluye un sistema de apertura y cierre empulsivo. Incluye un sistema de apertura y cierre empulsivo.

Ref. 107010 08 FINAVCO
Ref. 107010P 08 FINAVCO (COMPLETO)

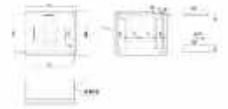

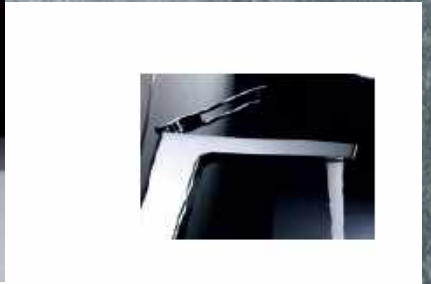

Cabe de litras: control y estabilidad que proporcionan confort y disfrute en cualquier baño.

GRIFERÍA DE COCINA



SAMOA NEGRO MATE

SERIE

REF. GCSD171NG

Grifería para lavavajillas

Características principales:

• Caudal de agua máximo de 12 l/min.

• Temperatura de agua: 30°C.

• Material: Cromo.

• Garantía: 5 años.

• País de origen: España.

• País de origen: España.



GRIFERIAS Y DUCHAS

 Infinity

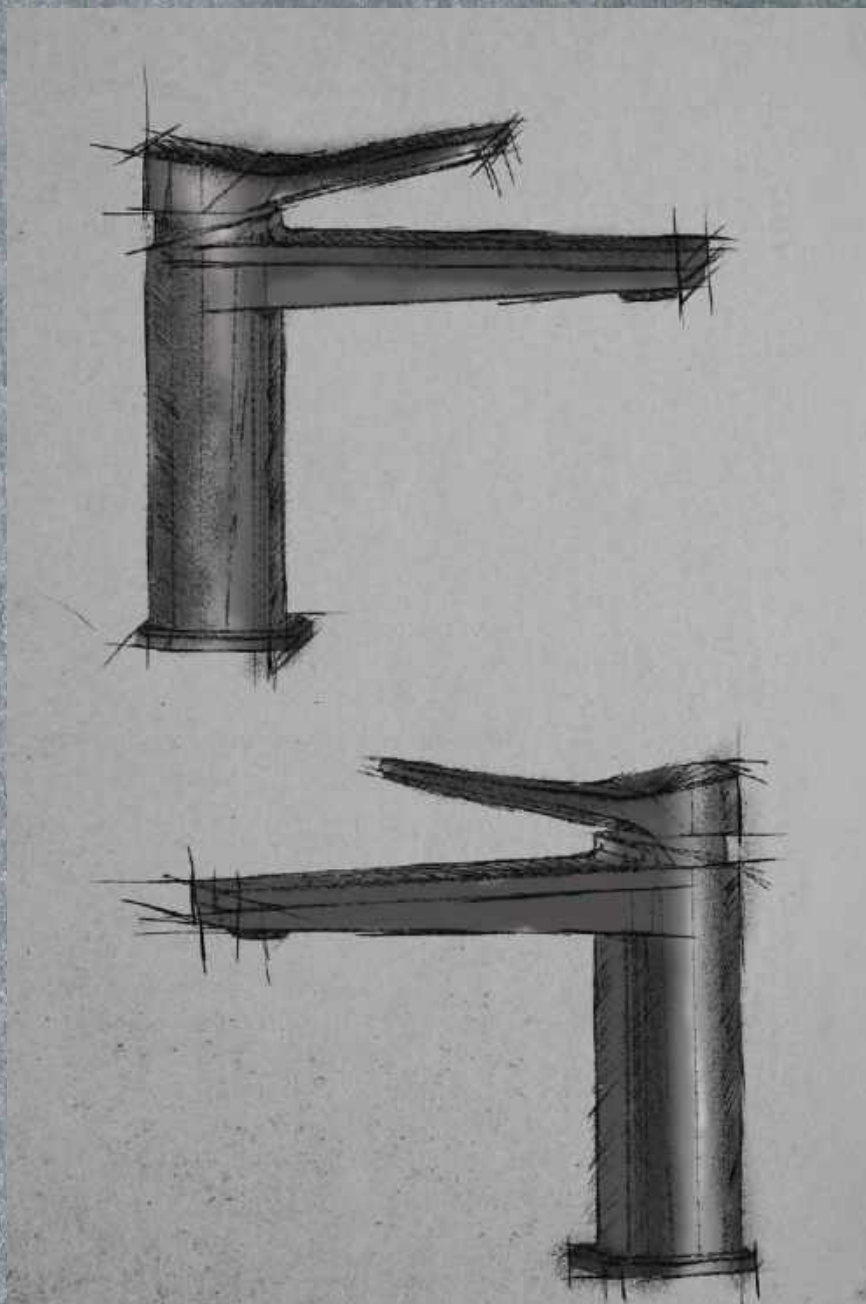

INCLINA COLLECTION

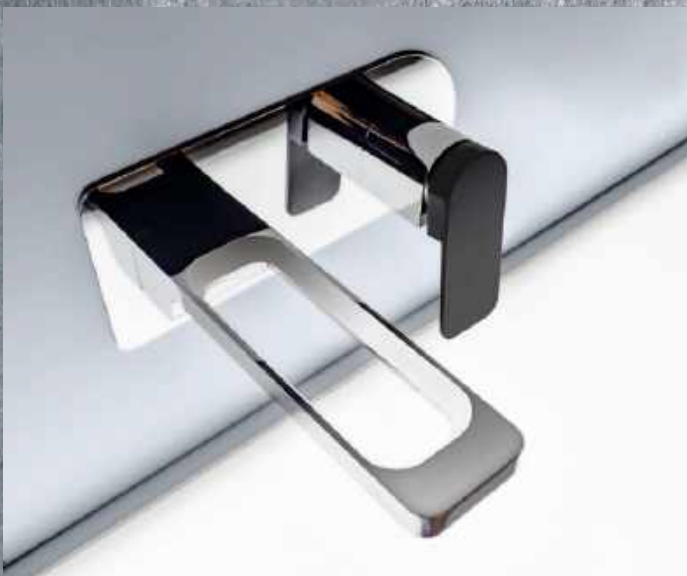

LIMITS COLLECTION



HIX COLLECTION



TEXTURES COLLECTION

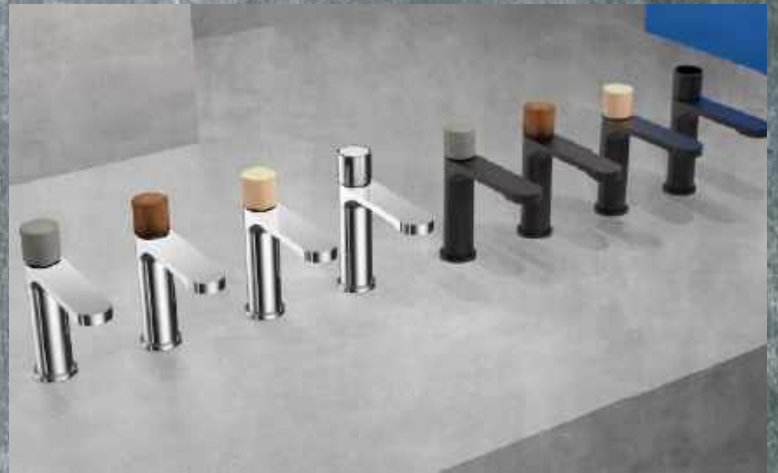

RONDO COLLECTION



FLOW COLLECTION



STICK COLLECTION



LUMIQ COLLECTION



NOVA COLLECTION



CONTRACT COLLECTION



VELA COLLECTION



BOX COLLECTION



PULSANTE COLLECTION

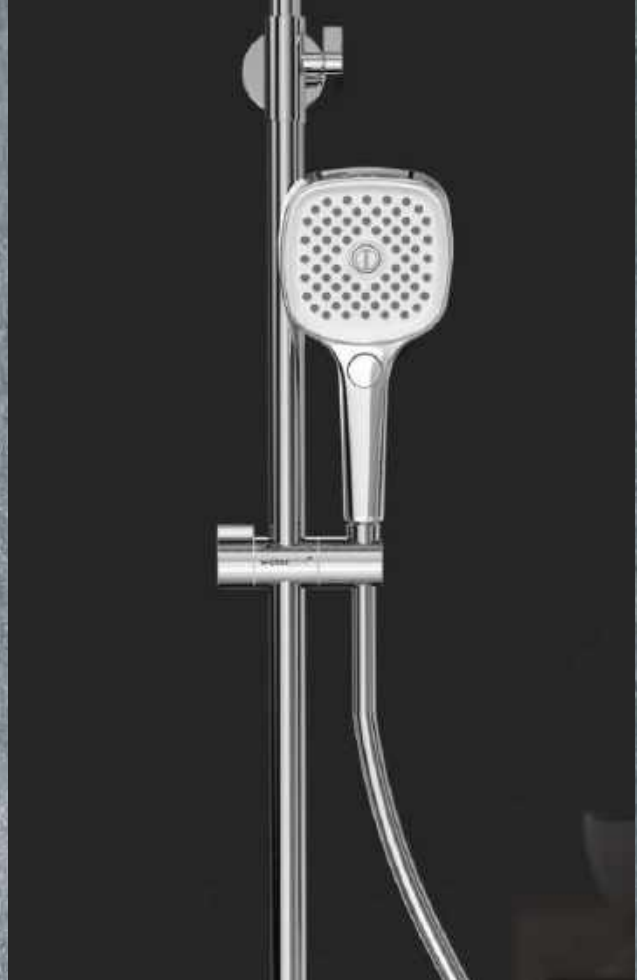

ELEMENTS SHOWERS



OVAL SHOWERS

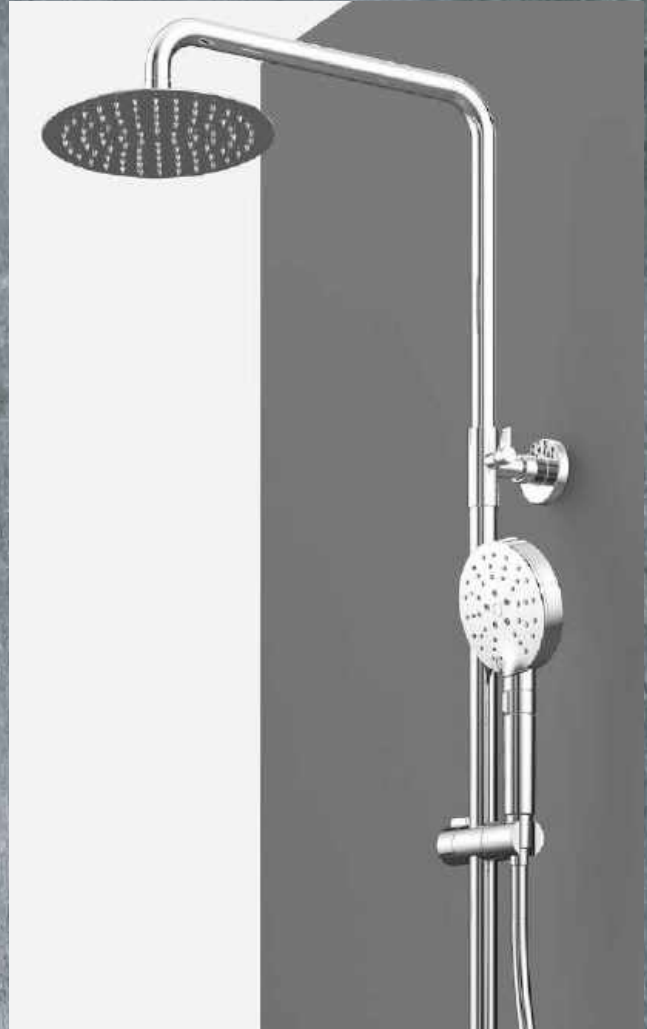

ROUND SHOWERS



WELLNESS COLLECTION



ESPEJOS LED.

"DISPONEMOS DE UNA AMPLIA GAMA DE ESPEJOS, CON UNA ESTÉTICA ELABORADA Y TECNOLÓGICAMENTE SUPERIORES, ADEMÁS DE UNA ESTUPENDA FUNCIONALIDAD, FABRICADOS CON LAS MAS ALTAS EXIGENCIAS EUROPEAS.

EN DUTXALIUM QUEREMOS SER MUCHO MÁS QUE UNA EMPRESA COMERCIALIZADORA, CUBRIENDO TODAS LAS NECESIDADES DE NUESTROS CLIENTES, ADEMÁS DE SER UN REFERENTE PARA ELLOS. EN NUESTRA COLECCIÓN DE ESPEJOS PARA ESTE CATÁLOGO, HEMOS CONSEGUIDO ELABORAR UNA AMPLIA GAMA DE PRODUCTOS , CON EL DISEÑO MAS ATRACTIVO DEL MERCADO Y TECNOLÓGICAMENTE SUPERIORES, ADEMÁS DE UNA ESTUPENDA FUNCIONALIDAD. TODO ESTO HACE QUE AFRONTEMOS EL FUTURO CON ILUSIÓN, COMPROMISO Y GARANTÍAS."



Producto

Nuestra empresa dispone de la tecnología más avanzada, junto con un equipo humano especializado en el sector, que nos proporciona una alta capacidad productiva puesta al servicio del cliente. Ser fabricantes nos permite adaptarnos a cualquier necesidad que nuestros clientes nos soliciten, con una esmerada calidad de producto y en constante desarrollo de las nuevas tecnologías del Mercado. Gracias a nuestra experiencia y polivalencia al ser fabricantes nos permite ofrecer espejos a medida diferenciándonos de esta forma de otros proveedores.



Equipo especializado

con más de 25 años de experiencia en el sector

En nuestras instalaciones disponemos de un departamento de I+D de producto para investigar la incorporación de las innovaciones tecnológicas a los espejos de baño, y de un departamento de Marketing, para analizar tendencias y necesidades y aplicarlo al desarrollo de nuestro producto. Todo esto nos permite tener flexibilidad y polivalencia para adaptarnos a las necesidades de nuestros clientes, dentro de un marco de la búsqueda de la excelencia y la calidad en nuestros productos.





Espejo / Mirror:
ANOUK 120 x 80 cm /   

Anouk

CM	W LED	LUMENS	W ANTIVAHQ W DEFOGGER
80x60	23.8	2380	16
100x80	31.4	3140	46
120x80	35.3	3530	70
140x80	39.1	3910	70



Producto disponible a medida
Measure available on request

Opciones / Options:



Ficha técnica / Technical sheet:



Acabado acero / Steel finish



Acabado negro / Black finish

Foto detalle trasera / Backside view



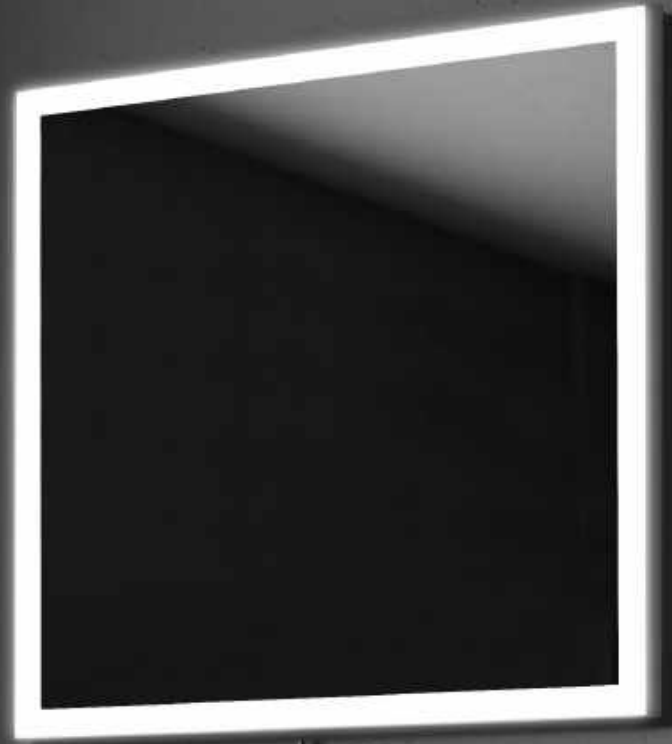

Espejo / Mirror:
ETNA 80 x 80 cm /

Etna

CM	W LED	LUMENS	W AKTYWNE/Opcje W obronieniu/Options
60x80	23.8	2380	16
100x80	31.4	3140	46
120x80	35.3	3530	70
140x80	39.1	3910	70



Producto disponible a medida.
Measures available on request

Opciones / Options:



Ficha técnica / Technical sheet



Acabado acero / Steel finish



Acabado negro / Black finish

Foto detalle trasera / Backside view





Espejo / Mirror:
KATIA 120 x 80 cm / ☺

Katia

CM	W LED	LUMENS	W ANTIHAHO / gora W DEFROSTER / ogreva
60x70	24	2400	16
80x70	28	2800	30
100x70	31	3100	46
120x70	35	3500	70



Producto disponible a medida.
Measure available on request

Opciones / Options:



Ficha técnica / Technical sheet



Foto de la parte trasera / Backside view



Espejo / Mirror:
AITANA 80 x 80 cm /

Aitana

CM	W LED	LUMENS	W ANTI-VAHÚ/opción W DEFOGGER/Optional
60x60	33	4640	16
80x80	39	5440	30
100x80	45	6240	46
120x80	57	7040	70



Producto disponible a medida
Measures available on request

Opciones / Options:



Ficha técnica / Technical sheet



Foto detalle trasero / Backside view



Espejo / Mirror:
EYRA 100 x 80 cm / © /

Eyra

CM	WLED	LUMENS	W. ANTIVAPOR/гигиена в паровоздуш. выводе.
60x80	23	2300	16
80x80	26.8	2680	30
100x80	30.7	3070	46
120x80	34.5	3450	70



Producto disponible a medida.
Measured available on request

Opciones / Options:



Ficha técnica / Technical sheet



Acabado acero / Steel finish



Acabado negro / Black finish

Foto detalle (reversa) / Backside view





Espejo / Mirror:
YVES 80 x 80 cm /

Yves 3led

CM	W LED	LUMENS	W ANTIVANDU/Opisla W ODPORNOŚĆ/Opisla
60x80	23	2300	16
80x80	26.8	2680	30
100x80	30.7	3070	46
120x80	34.5	3450	70



Producto disponible a medida.
Measure available on request

Opciones / Options:



Ficha técnica / Technical sheet



Foto detalle travesera /
Backside view



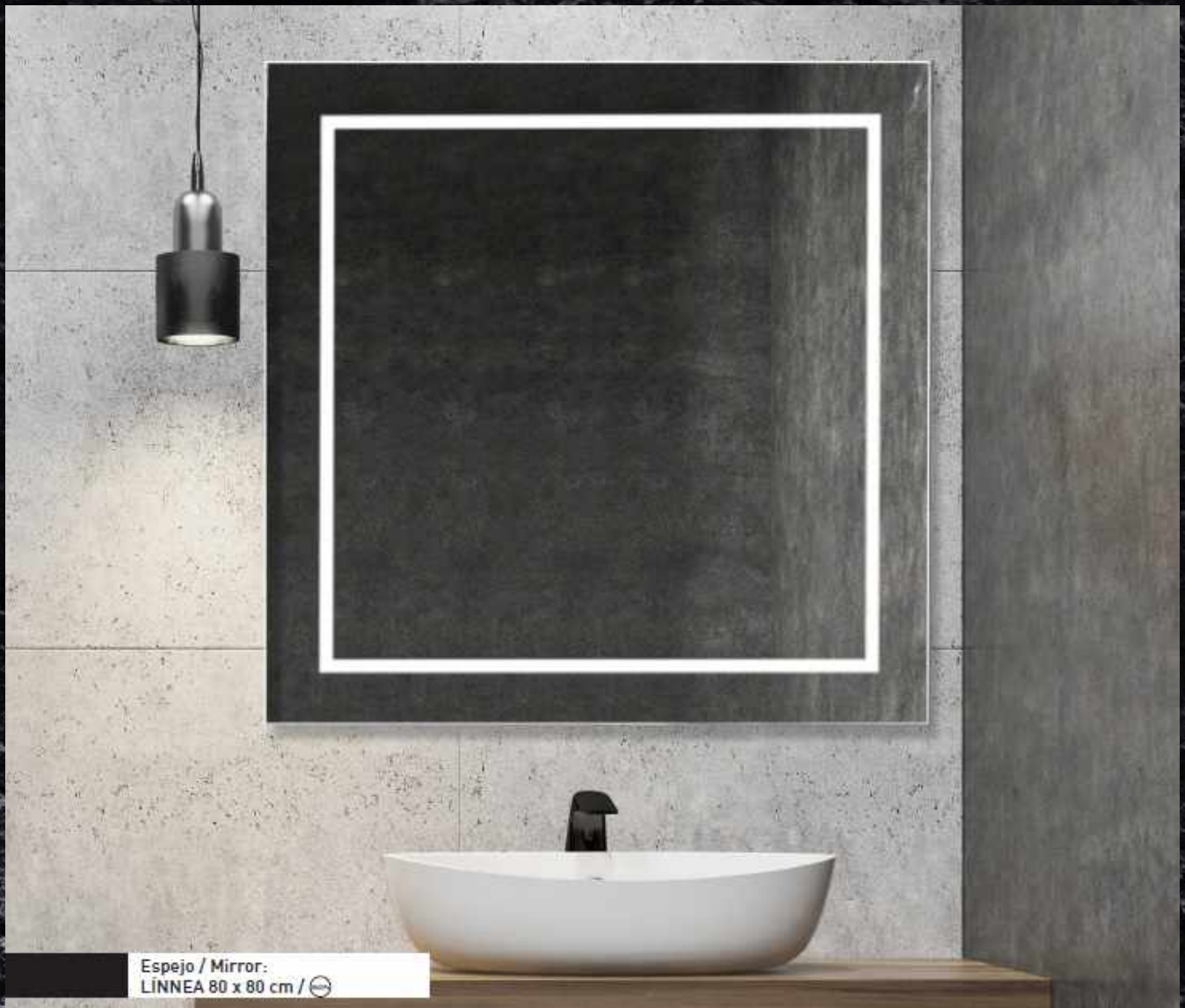

Espejo / Mirror:
LÍNNEA 80 x 80 cm / ☹

Línnea LED

CM	W LED	LUMENS	W ANTI/VAPO/Opção e W DEFOGUE/Opções
60x80	19.9	1990	16
80x80	23.8	2380	30
100x80	27.6	2760	46
120x80	31.4	3140	70



Producto disponible a medida.
Measures available on request

Opciones / Options:



Ficha técnica / Technical sheet:



Foto detalle trasera / Backside view

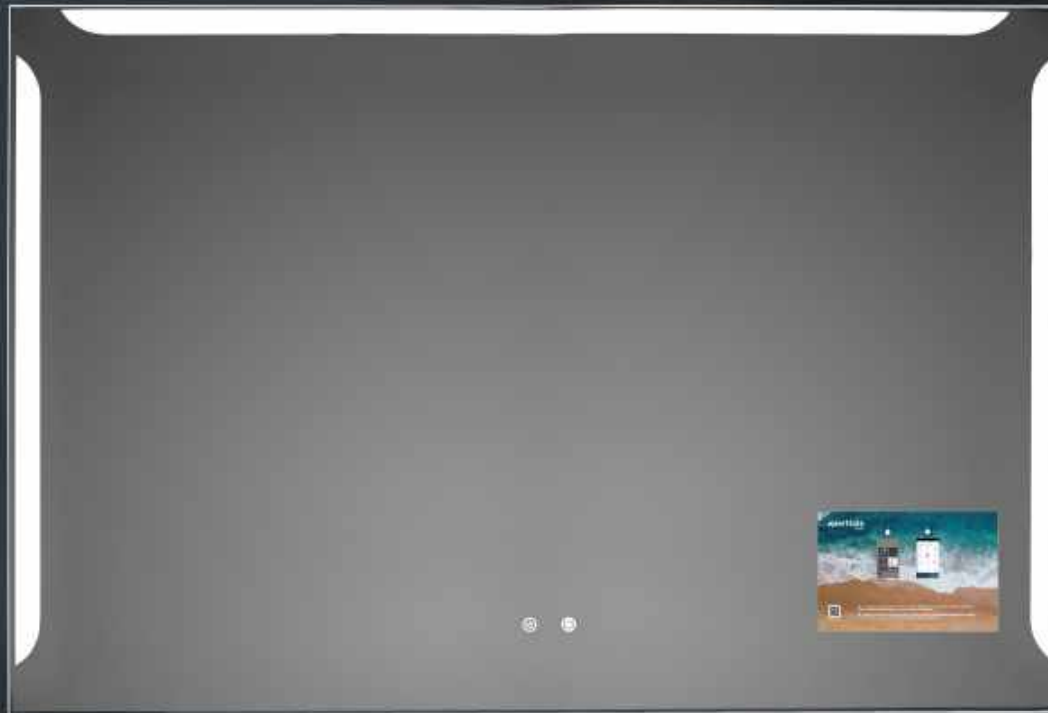

Espejo / Mirror:
ALICE Screen 120 x 80 cm / ☉ / ☉ / ☉

Alice Screen mirror

CM	W LED	LUMENS	WARIANTY OPCJE W DŁUGOŚCI / Options
80x80	20.7	2070	30
100x80	22.6	2260	30
120x80	24.5	2450	60
140x80	26.4	2640	60



Produkt dostępne a medida
Measure available on request

Opciones / Options:



Ficha técnica / Technical sheet





Espejo / Mirror:
ALICE 120 x 80 cm / ☉

Alice

CM	W LED	LUMENS	WARRANTY/Opciones W Opcjach/Opciones
60x80	16.8	1680	16
80x80	20.7	2070	30
100x80	22.6	2260	46
120x80	24.5	2450	70



Producto disponible en medida
Measure available on request

Opciones / Options:



Ficha técnica / Technical sheet



Acabado acero / Steel finish



Acabado negro / Black finish

Foto detalle trasera / Back side view



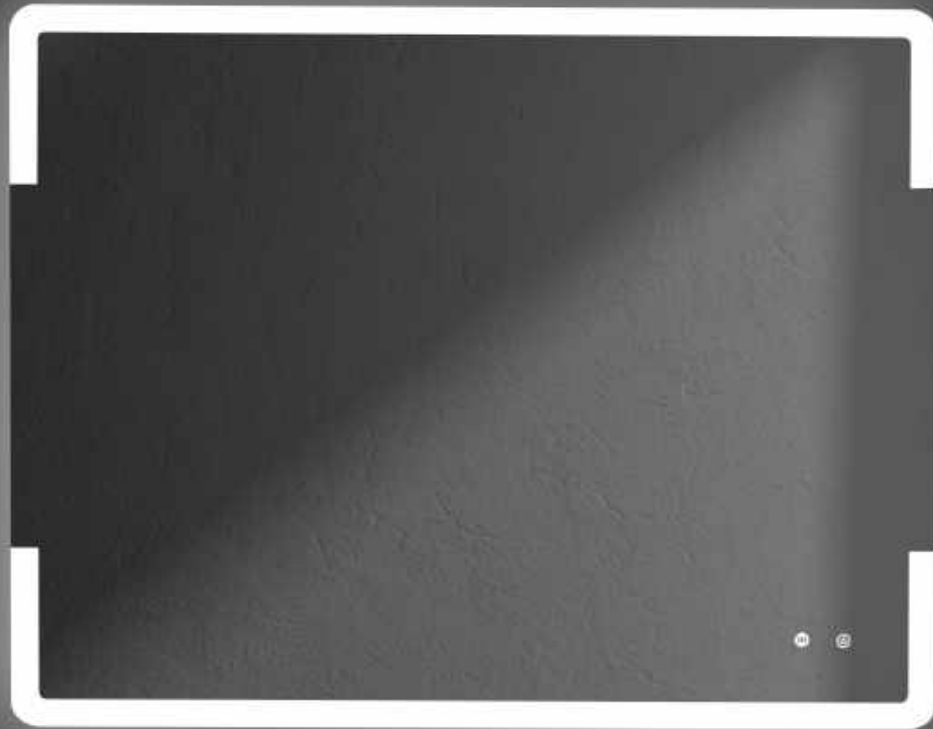

Espejo / Mirror:
Marte 120 x 80 cm / ☉ / 📶 / 🎵 / 🚿

Marte

CM	W LED	LUMENS	WARRANTY/years WARRANTER/Optimas
60x80	22.9	2200	16
80x80	25.9	2590	30
100x80	29.7	2970	46
120x80	33.6	3360	70
140x80	37.4	3740	70



Producto disponible a medida.
Measures available on request

Opciones / Options:



Ficha técnica / Technical sheet



Foto detalle trasera / Backside view



Espejo / Mirror:
EIVOR 80 x 80 cm / ⊖

Eivor

CM	W LED	LUMENS	W ANTIVOSMO/opcja a W ODPOROWOSC ploska
60x80	22.9	2200	16
80x80	25.9	2590	30
100x80	29.7	2970	46
120x80	33.6	3360	70
140x80	37.4	3740	70



Producto disponible a medida -
Measured available on request

Opciones / Options:



Ficha técnica / Technical sheet



Foto detalle trasera / Backside view



Espejo / Mirror:
OSNA 120 x 80 cm / ☹

Osna

CM	W LED	LUMENS	W ANTIUMBO/egula W oztromoc/egula:
60x80	8.6	860	16
80x80	12.4	1240	30
100x80	16.3	1630	46
120x80	20.1	2010	70
140x80	24.0	2400	70



Producto disponible a medida -
Measures available on request

Opciones / Options:



Ficha técnica / Technical sheet



Acabado acero / Steel finish



Acabado negro / Black finish

Foto detalle trasera / Backside view





Espejo / Mirror:
KAMET 100 x 80 cm /

Kamet

CM	W LED	LUMENS	WARRANTY / Garantia W DEFECTOS / Garantia
60x80	21.5	2150	18
80x80	24	2400	30
100x80	29.1	2910	46
120x80	33.3	3330	70
140x80	36.9	3690	70



Producto disponible a medida.
Measures available on request.

Opciones / Options:



Ficha técnica / Technical sheet



Foto detalle trasero / Back-side view



Espejo / Mirror:
EMIN 120 x 80 cm / ☉

Emin

CM	W LED	LUMENS	W ANTIVAPOR / Espuma W DEPODAR / Espuma
60x80	23.8	2380	16
80x80	27.6	2760	30
100x80	31.4	3140	46
120x80	35.3	3530	70



Producto disponible a medida.
Measure available on request.

Opciones / Options:



Ficha técnica / Technical sheet:



Acabado acero / Steel finish



Acabado negro / Black finish

Foto detalle trasera / Backside view





Espejo / Mirror:
GREDOS 120 x 80 cm / ☺

Gredos

CM	W LED	LUMENS	WANTNARO/Цикл W DEPODCH/Эквивал
60x80	11.5	1150	16
80x80	15.3	1530	30
100x80	19.2	1920	46
120x80	23	2300	70



Producto disponible a medida
Measures available on request

Opciones / Options:



Ficha técnica / Technical sheet



Foto detalle trasero / Backside view



Espejo / Mirror:
ARAN 60 x 80 cm /

Aran

CM	W LED	LUMENS	W ANTIUMBURO/INCL & W DEFROST/W/ST-VAL
60x80	15.3	1530	16
80x80	15.3	1530	30
100x80	15.3	1530	46
120x80	15.3	1530	70



Producto disponible a medida.
Measures available on request

Opciones / Options:



Ficha técnica / Technical sheet



Foto detalle travesa / Backside view



Espejo / Mirror:
ILSE 80 x 80 cm / ☺

Ilse

CM	W LED	LUMENS	W ANTIFOG/Options W DEFODER/optional
60x80	15.3	1530	16
80x80	15.3	1530	30
100x80	15.3	1530	46
120x80	15.3	1530	70



Producto disponible a medida.
Measures available on request

Opciones / Options:





Ficha técnica / Technical sheet



Foto detalle trasera / Back-side view



Espejo / Mirror:
SVEN 80 x 80 cm /  / 

Sven

CM	W LED	LUMENS	W ANTIVANHO/OPCIÓN W DEFOUSER/OPTIONAL
60x80	11.5	1150	16
80x80	15.3	1530	30
100x80	19.2	1920	46
120x80	23	2300	70



Producto disponible a medida.
Measure available on request.

Opciones / Options:



Ficha técnica / Technical sheet



Foto detalle trasera / Back-side view



Espejo / Mirror:
ASTRO 100 x 80 cm /   

Astro

CM	W LED	LUMENS	W antilleno/tycja W zeroocen/tycja
80x80	23	2300	16
100x80	26.8	2680	46
120x80	30.7	3070	70
140x80	34.5	3450	70



Producto disponible a medida
Measures available on request

Opciones / Options:



Ficha técnica / Technical sheet



Foto detalle trasera / Backside view

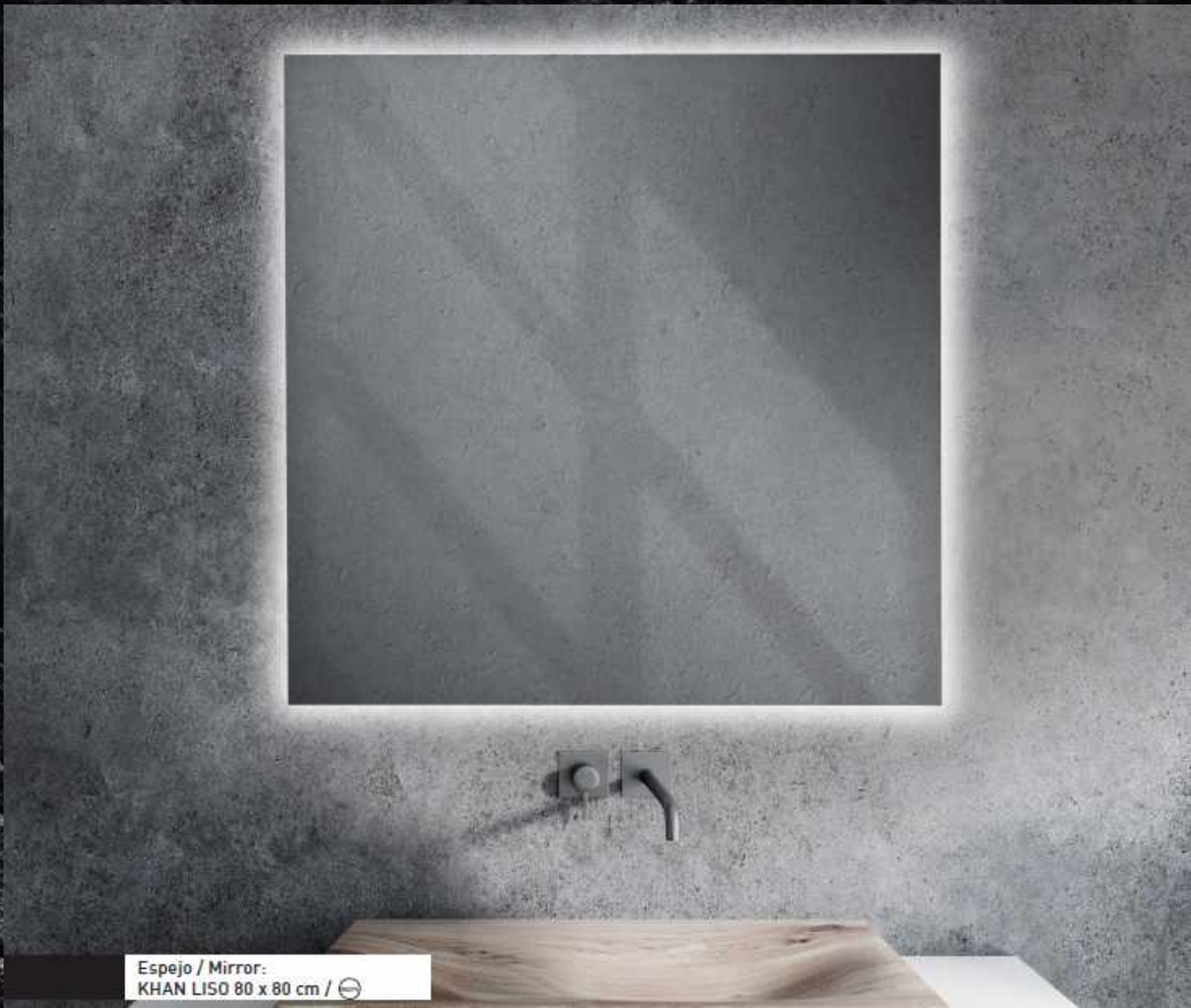

Espejo / Mirror:
KHAN LISO 80 x 80 cm / ☺

Khan Liso

CM	W LED	LUMENS	W ANTIVANDALOJE poka- W DEPOZICJE / signs out
60x80	24	2400	16
80x80	28	2800	46
100x80	32	3200	70
120x80	36	3600	70



Producto disponible e medido:
Measures available on request

Opciones / Options:



Ficha técnica / Technical sheet



Foto detalle trasero / Backside view

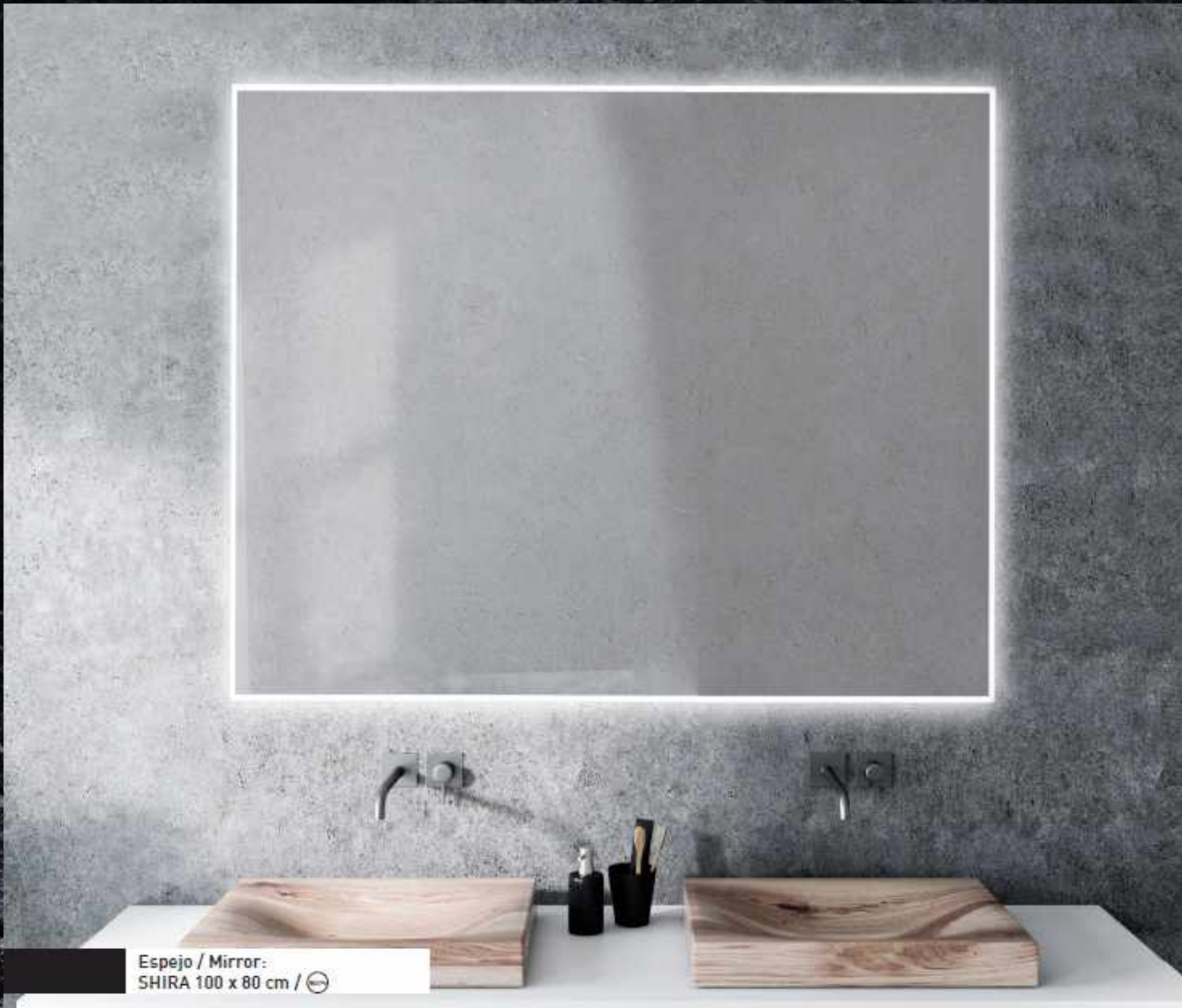

Espejo / Mirror:
SHIRA 100 x 80 cm / ☹

Shira

CM	W LED	LUMENS	W ANTIKVAH/Specis W DEFODNER/Optional
60x80	24	2400	16
80x80	28	2800	46
100x80	32	3200	70
120x80	36	3600	70



Producto disponible a medida
Measures available on request

Opciones / Options:



Ficha técnica / Technical sheet



Foto detalle trasera / Backside view



Espejo / Mirror:
SHIRA 100 x 80 cm /

Shira Aumento 5x

CM	W LED	LUMENS	W ANTIVANHO/espuma W DEFODGER/foam
80x80	41	4100	30
100x80	44	4400	46
120x80	48	4800	70



Producto disponible a medida
Measure available on request

Opciones / Options:



Ficha técnica / Technical sheet



Espejo Aumento 5x / 5x magnifying mirror



Foto detalle trasero / Backside view



Espejo / Mirror:
AMIRA 60 x 80 cm /

Amira

CM	W LED	LUMENS	W ANTI-VAPORE/Agua W D'UMIDITÀ/Relative
60x80	23.7	2390	16
80x80	28	2800	30
100x80	32	3200	46
120x80	36	3600	70



Opciones / Options:



Ficha técnica / Technical sheet:



Foto detalle travesera / Backside view.



Espejo / Mirror:
VENUS 600 cm / 

Venus

CM	W LED	LUMENS	W EXTRAIO/Espejo x W DCPOBCH/Экран
60 Ø	14.4	1440	10
80 Ø	20.6	2060	16



Opciones / Options:



Ficha técnica / Technical sheet:



Foto detalle trasero / Backside view



Espejo / Mirror:
HELIX 80x70 cm / 

Helix

CM	W LED	LUMENS	W ANTIVANHO / Opção W DEFODDER / Opção
80x70	17	1700	16



Opciones / Options:



Ficha técnica / Technical sheet



Foto detalle trasera / Backside view



Espejo / Mirror:
URANO 80 cm / 

Urano

CM	W LED	LUMENS	W ANTIUMBO/egüla W DFP000CR/Optimat
60	16.8	1680	10
80	21.7	2170	16



Opciones / Options:



Ficha técnica / Technical sheet



Foto detalle trasera / Backside view



Espejo / Mirror:
PLUTON 80 cm / 

Plutón

CM	W LED	LUMENS	W ANTI/VR/0/Options W ODF/000CR/0/Optional
60	14.4	1440	10
80	20.6	2060	16



Opciones / Options:



Ficha técnica / Technical sheet



Foto detalle trasero / Backside view



Espejo / Mirror:
IRIS 80 Ø cm / 

Iris

CM	W LED	LUMENS	W ANTIKONDENSACIÓN W DEPOSIÇÃO/防結露
60 Ø	14.4	1440	10
80 Ø	20.6	2060	16



Opciones / Options:



Ficha técnica / Technical sheet



Foto detalle trasera / Back side view



Espejo / Mirror:
DUARTE 80 Ø cm / 

Duarte

CM	W LED	LUMENS	W ANTIVANHO / Cycle W DEFROSTER / Optimal
60 Ø	14,4	1440	10
80 Ø	20,6	2060	16



Opciones / Options:



Ficha técnica / Technical sheet



Foto doblada trasera / Backside view



Espejo / Mirror:
LANX 80 x 80 cm

Lanx

CM	W LED	LUMENS	W ANTIVAPOR/Epoca x W DEFOGUEIR/Epoca x
60 x 60	14.4	1440	10
80 x 80	20.6	2060	16



Producto disponible a medida.
Measures available on request

Opciones / Options:



Ficha técnica / Technical sheet:



Foto detalle trasera / Back side view



Espejo / Mirror:
SASER 80 Ø cm / ☉

Saser

CM	W LED	LUMENS	W ANTIVANCO/poco W DEFOGGER/ghost
60 Ø	16.8	1680	10
80 Ø	21.7	2170	16



Opciones / Options:



Ficha técnica / Technical sheet:



Foto detalle trasera / Backside view.



Espejo / Mirror:
 SPHERE 70 Ø cm / ☉ / ☽

Sphere

CM	W LED	LUMENS	W ANTIKHAPOB/eye c. W DEPOBACH/eyes at
70 Ø	16.8	1680	10
90 Ø	21.7	2170	16



Opciones / Options:



Ficha técnica / Technical sheet



Foto detalle trasero / Backside view



Espejo / Mirror:
LUMIX 70 Ø cm / 

Lumix

CM	W LED	LUMENS	W ANTIVIBRO/Opción W OZP00000R/Optional
70 Ø	16.8	1680	10
90 Ø	21.7	2170	16

Opciones / Options:



Ficha técnica / Technical sheet



Foto apertura trasera / Backside view

Espejo / Mirror:
SIRO 80 Ø cm / 

Siro

CM	W LED	LUMENS	W ANTICAHUMOS PCRS W DEFOGGER/AgGlass
60 Ø	18.10	1810	10
70 Ø	21.11	2111	10
80 Ø	24.13	2413	30
90 Ø	27.14	2714	46
100 Ø	30.16	3016	16

Opciones / Options:



Ficha técnica / Technical sheet



Foto detalle trasera / Backside view



Espejo / Mirror:
ZOILA 80 x 60 cm /

Zoila

CM	W LED	LUMENS	W ANTIVAPOR y otros W DEFROGEE / optional
80x60	20	2000	16



Opciones / Options:



Ficha técnica / Technical sheet



Foto detalle trasera / Backside view



Espejo / Mirror:
KOREN 100 x 70 cm /    

Koren 3led

CM	W LED	LUMENS	W ANTIYAHQ/Opciones W DEFOGGER/Optional
100X70	28.8	7540	16

Opciones / Options:



Ficha técnica / Technical sheet



Foto de la lámpara trasera /
Backlight view

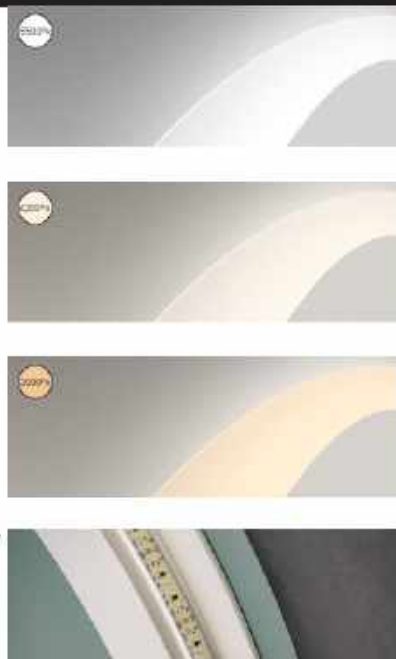

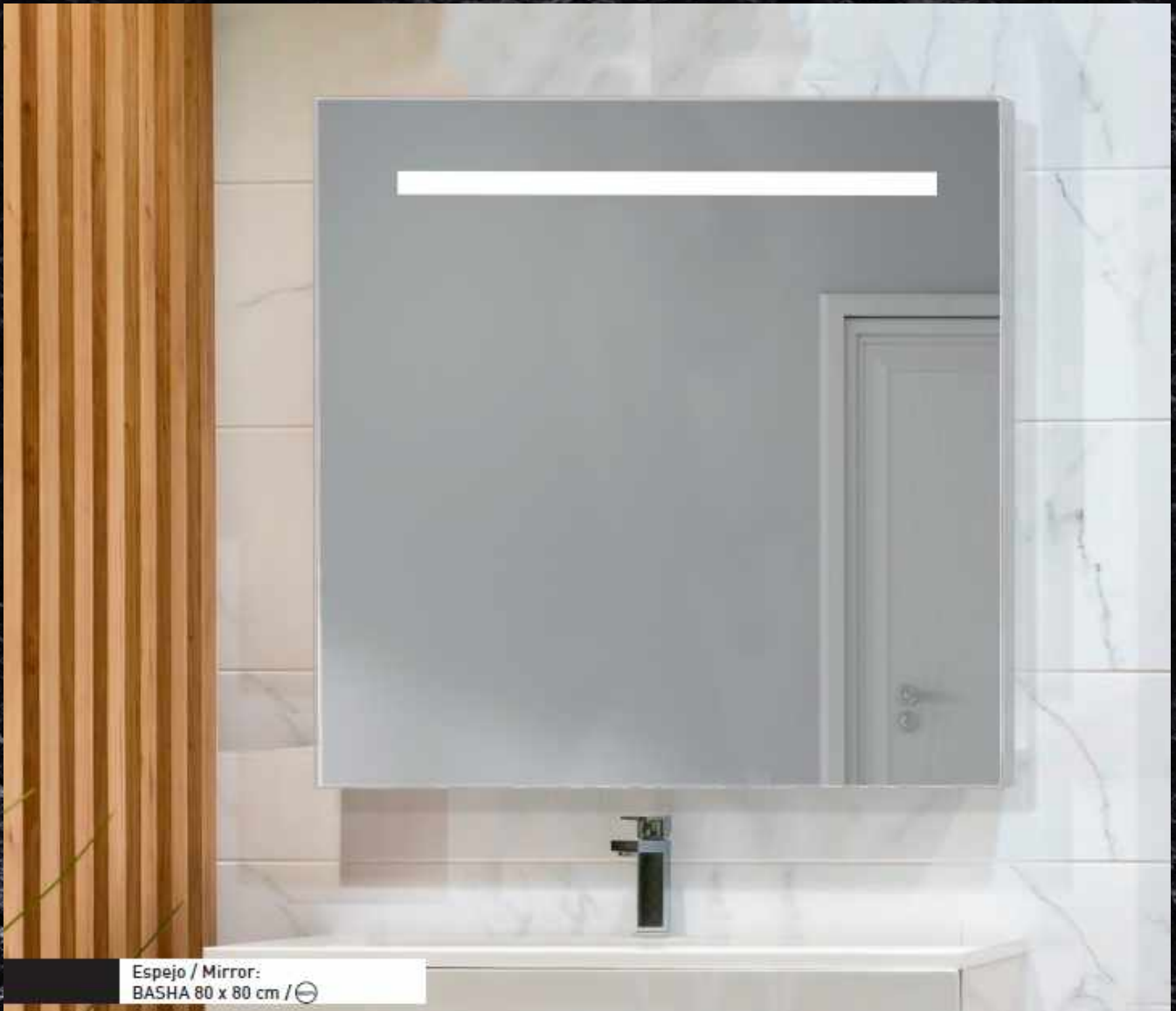

Espejo / Mirror:
BASHA 80 x 80 cm /

Basha

CM	W LED	LUMENS	W ANTIHABO/Opcja W DEFOSFER/Opzioni
60x80	5.1	510	16
80x80	7.1	710	30
100x80	9	900	46
120x80	10.9	1090	70



Producto disponible a medida
Measure available on request

Opciones / Options:



Ficha técnica / Technical sheet:



Acabado acero / Steel finish



Acabado negro / Black finish

Foto detalle trasera / Backside view



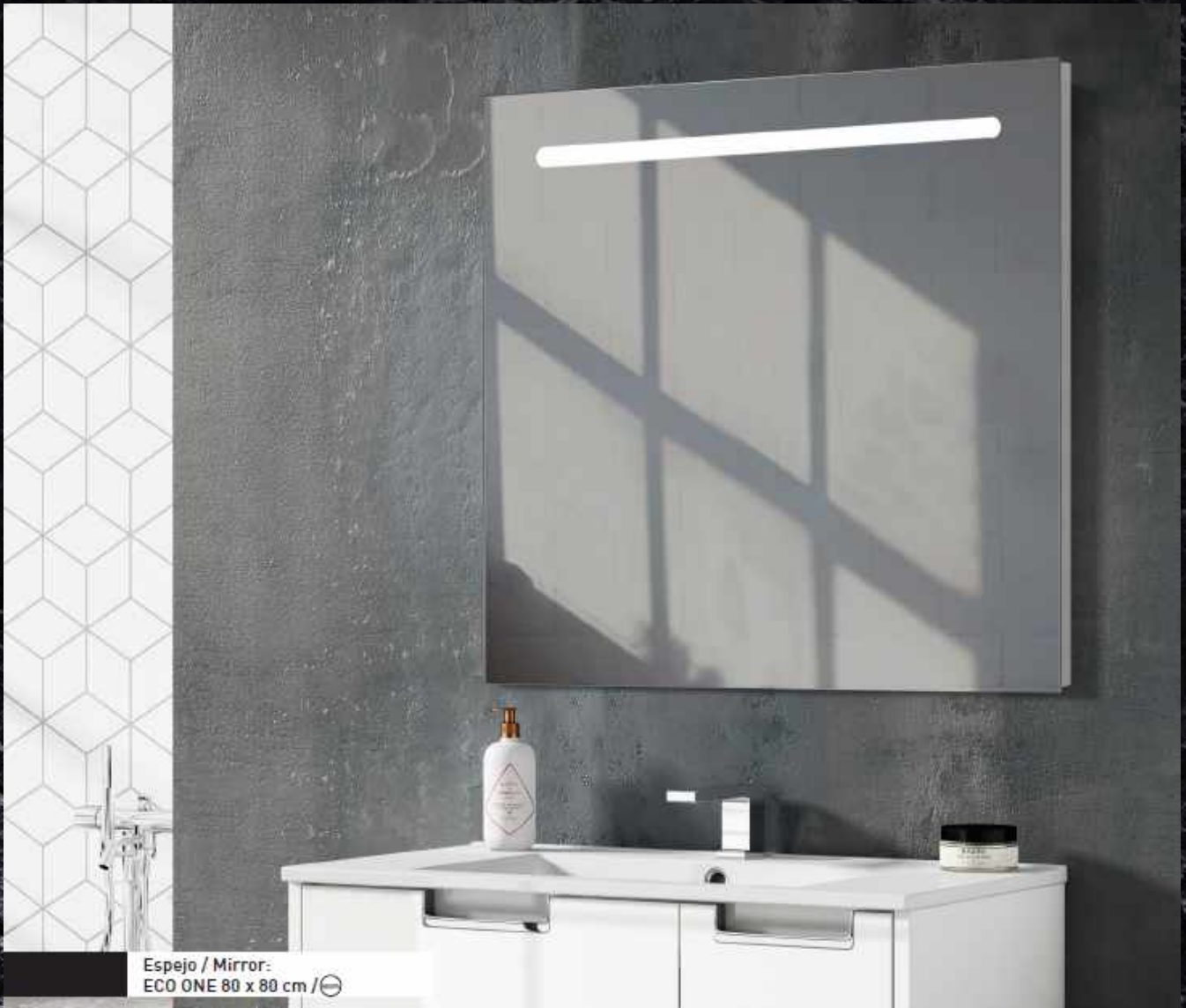

Espejo / Mirror:
ECO ONE 80 x 80 cm / ⊕

Eco one led

CM	W LED	LUMENS	W ANTIVIBR./opción a W DEPENDENCIA precio
60x80	4.3	430	16
80x80	6.2	620	30
100x80	8.1	810	46
120x80	10	1000	70



Producto desmontable a medida.
Measures available on request.

Opciones / Options:



Ficha técnica / Technical sheet



Foto detalle trasera / Backside view.



Espejo / Mirror:
ECO TWO 80 x 80 cm / 

Eco two led

CM	W LED	LUMENS	W ANTIWANO/opcja a W DEPONDOSKIE plosku
60x80	13.5	1350	16
80x80	13.5	1350	30
100x80	13.5	1350	46
120x80	13.5	1350	70
140x80	13.5	1350	70



Producto disponible a medida.
Measures available on request

Opciones / Options:



Ficha técnica / Technical sheet



Foto de la parte trasera / Backside view



Espejo / Mirror:
HERMES 100 x 80 cm /

Hermes

CM	W LED	LUMENS	W. ANTIVANOS/Opção W. DEPOSDOER/Opção 2
60x80	5,76	576	16
80x80	7,68	768	30
100x80	9,60	960	46
120x80	11,58	1158	70



Marco metálico acabado cromo / Metallic frame chrome finish



Marco metálico acabado negro / Metallic frame black finish

Opciones / Options:



Ficha técnica / Technical sheet





Espejo / Mirror:
OLEK R 60 Ø cm /

Olek R

CM	W ANTIVANOS/Opciones W DIFUSORES/Opciones
60	10
80	16



Marco metálico acabado cromo / Metallic frame chrome finish



Marco metálico acabado negro / Metallic frame black finish

Opciones / Options:



Ficha técnica / Technical sheet





Espejo / Mirror:
OLEK C 120 x 80 cm / ☺

Olek C LED

CM	W LED	LUMENS	W ANTIVARCO/poca s W DEFODOR/0 p/120s
60 x 80	26.88	26.88	16
80 x 80	30.72	30.72	30
100 x 80	34.56	34.56	46
120 x 80	38.40	38.40	70

Opciones / Options:



Ficha técnica / Technical sheet



Marco metálico acabado cromo / Metallic frame chrome finish





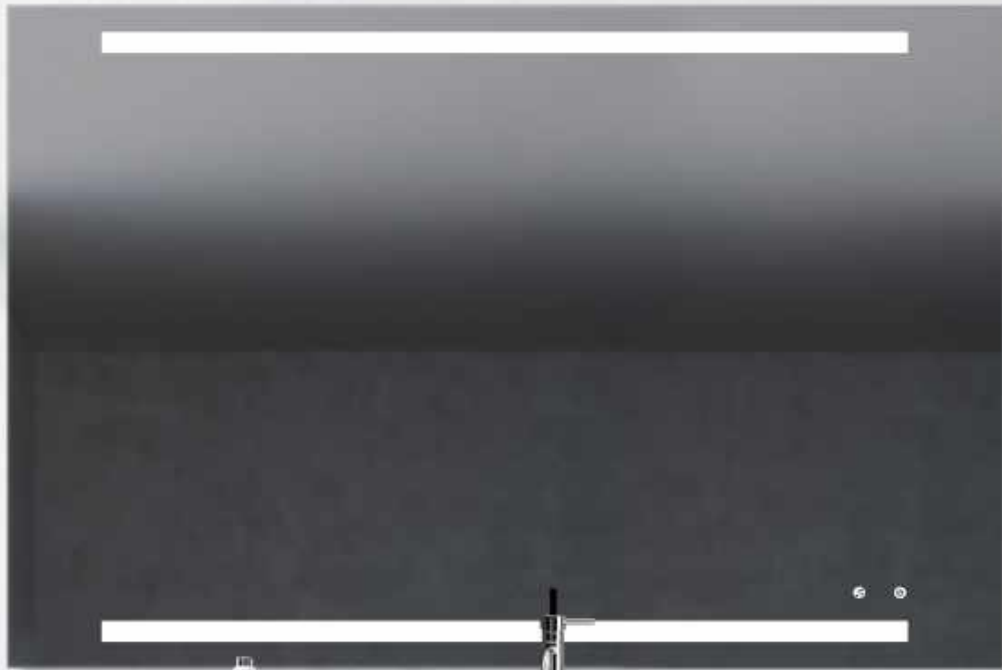

Marco metálico acabado negro / Metallic frame black finish

Foto detalle trasera / Backside view





Espejo / Mirror:
ARION 120 x 80 cm /    

Arion

CM	W LED	LUMENS	W. EXTRA/LED extra w. DEPOZIT/LED extra
60x80	9.9	990	16
80x80	13.8	1380	30
100x80	17.6	1760	46
120x80	21.5	2150	70



Producto disponible a medida.
Measures available on request

Opciones / Options:



Ficha técnica / Technical sheet:



Foto detalle trasera /
Backside view





Espejo / Mirror:
CLAIRE 80 x 80 cm /

Claire 3led

CM	W LED	LUMENS	WARRANTY/years W DEFODDER/years at
60x80	8.9	890	16
80x80	12.7	1270	30
100x80	16.6	1660	46
120x80	20.3	2030	70



Producto disponible a medida
Measures available on request

Opciones / Options





Ficha técnica / Technical sheet



Foto detalle fresta /
Backside view





Espejo / Mirror:
DAPHNE 80 x 80 cm /  / 

Daphne

CM	W LED	LUMENS	WANTIVARIO/Opcio W DEPÓSITO/Optional
60x80	13.6	1360	16
80x80	13.6	1360	30
100x80	13.6	1360	46
120x80	13.6	1360	70



Producto disponible a medida:
Measure available on request

Opciones / Opciones:



Ficha técnica / Technical sheet



Acabado cromo / Chrome finish



Acabado negro / Black finish

Nuevo sistema touch lateral
New lateral touch system

Foto detalle trasera / Backside view





Espejo / Mirror:
CADIER 45 x 90 cm / ☺

Cadier 45

CM	W LED	LUMENS	W ANTIVAPOR/9000h W DOPÓDROBIEK/9000h
45x90	13	1300	16



Acabado acero/ Steel finish



Acabado negro/ Black finish

Opciones / Options:



Ficha técnica / Technical sheet



Foto detalle trasero / Backside view





Espejo / Mirror:
NANGA 80 x 80 cm /

Nanga

CM	W LED	LUMENS	W ANTIVAHOROSCHN W DEFROSTER/Optional
60x80	9.9	990	16
80x80	13.8	1380	30
100x80	17.6	1760	46
120x80	21.5	2150	70



Producto disponible a medida.
Measure available on request

Opciones / Options:



Ficha técnica / Technical sheet:



Acabado acero, luz fría / Steel finish, cold light



Acabado negro, luz cálida / Black finish, warm light

Foto detalle trasera / Backside view





Espejo / Mirror:
OLEK R 60 Ø cm / ☉ / ☉

Olek R LED

CM	W LED	LUMENS	W АНТРАЖИ/Всичка. W ДЕРЖИТЕЛИ/оптика
60 Ø	18.10	1810	10
80 Ø	24.13	2413	16



Marco metálico acabado cromo / Metallic frame chrome finish



Marco metálico acabado negro / Metallic frame black finish

Opciones / Options:



Ficha técnica / Technical sheet



Foto detalle trancora / Backside view





Espejo / Mirror:
OLEK C 60 x 80 cm /

Olek C

CM	W zmontowaniu/epoksyd w narożniku/epoksyd
60x80	16
80x80	30
100x80	46
120x80	70



Marco metálico acabado cromo / Metallic frame chrome finish



Marco metálico acabado negro / Metallic frame black finish

Opciones / Options:



Ficha técnica / Technical sheet





Espejo / Mirror:
VULCANO 80 x 80 cm / ☺ / ☹ / ☹ / ☹

Vulcano 3led

CM	W LED	LUMENS	WARRANTY/Garantía W DEFUGGER/Optimas
60x80	19.60	1960	16
80x80	23.04	2304	30
100x80	24.96	2496	45
120x80	26.88	2688	70

Opciones / Options:



Ficha técnica / Technical sheet



Foto detalle trasera / Backside view





Espejo / Mirror:
ALBA 60 x 80 cm

Alba

CM	W LED	LUMENS	W АКТИВНО/актив W ДИРОДНО/диодна
60x80	4.8	480	16



Acabado cromo / Chrome finish



Acabado negro / Black finish

Opciones / Options:



Ficha técnica / Technical sheet:





Espejo / Mirror:
BLACK 60 x 80 cm /

Black

CM	W LED	LUMENS
60x80	4 B	480



Borda metálica acabada negra / Metallic shell black finish

Opciones / Options:



Ficha técnica / Technical sheet





Espejo / Mirror:
MILAN 60 x 75 cm

Milan

CM	W LED	LUMENS	W ANTIVAHU/egcior W DEPOSOER/Optional
60x75	4	400	16



Acabado cromo / Chrome finish

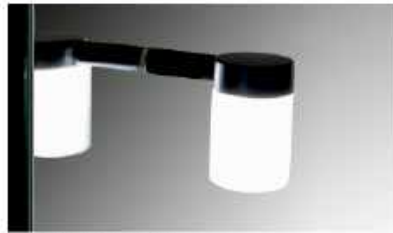

Acabado negro / Black finish

Opciones / Options:



Ficha técnica / Technical sheet





Espejo / Mirror:
BASIC 120 x 80 cm

Basic

CM	W ZMITYKANO/в сантиметрах W ДОВОДЦІ/в сантиметрах
60x80	16
80x80	30
100x80	46
120x80	70



Producto disponible a medida
Measures available on request

Opciones / Options:



Ficha técnica / Technical sheet

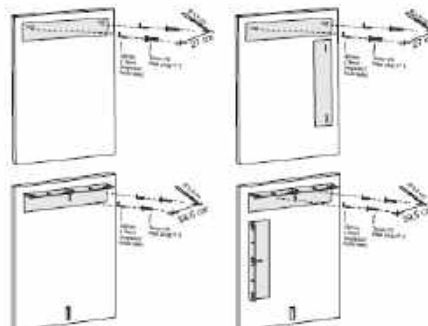



Espejo / Mirror:
AGNETA 80X80 cm /

Agneta

CM	W ANTIVANOS/espacia W DE FUCOSAS/Opções
60x80	16
80x80	36
100x80	46
120x80	70



Producto disponible a medida.
Measures available on request.

Opciones / Options:



Ficha técnica / Technical sheet



Acabado acero/ Steel finish



Acabado negro/ Black finish



Espejo / Mirror:
BELICE 80 x 80 cm

Belice

CM	W ANTYKOROZYJNE W DEKORACJI (mm)
60x80	16
80x80	30
100x80	46
120x80	70



Producto disponible a medida
Measure available on request



Opciones / Options:



Ficha técnica / Technical sheet

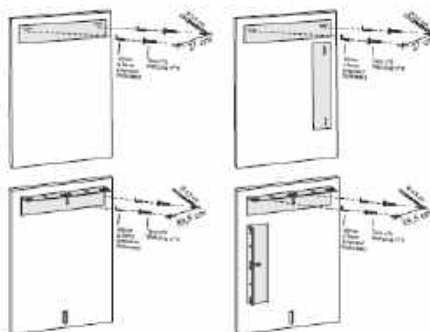



Espejo / Mirror:
MENORCA 100 x 80 cm

Menorca

CM	WANTYAHIO/egrisa W DEFONDER/Ophtical
60x80	16
80x80	30
100x80	46
120x80	70



Producto disponible a medida
Measures available on request

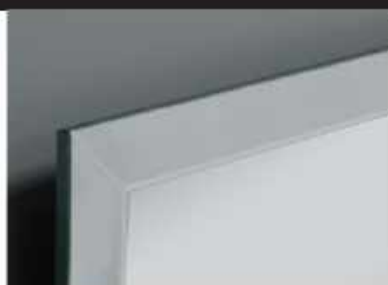

Opciones / Options:



Ficha técnica / Technical sheet

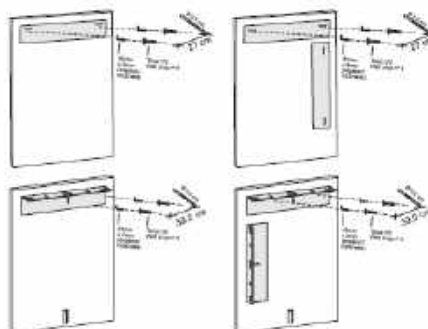



Espejo / Mirror:
ROMO 80 x 80 cm

Romo

CM	W ANTIVAHIO/espina W DEFROGGER/Spix nail
60x80	16
80x80	30
100x80	46
120x80	70



Producto disponible a medida.
Measure available on request



Opciones / Options:



Ficha técnica / Technical sheet

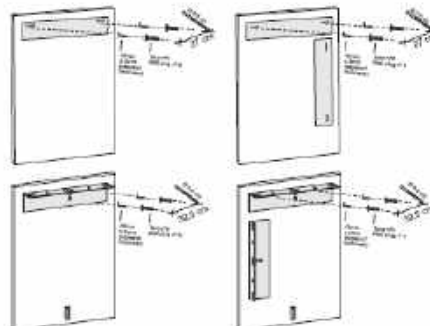

Altair 30 cm



Altair 50 cm



Altair LED

MEDIDAS	WATIOS LED	LUMENS
30cm	4.8	400
50cm	7	1080

Acabados/finishes:
Cromo / Chrome

Ficha técnica / Data sheet



Doble sistema de fijación / Dual fixation system

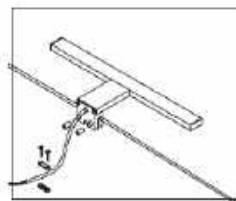

Espejo
Mirror

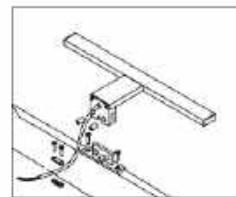

Espejo
Mirror

Drop 30 cm

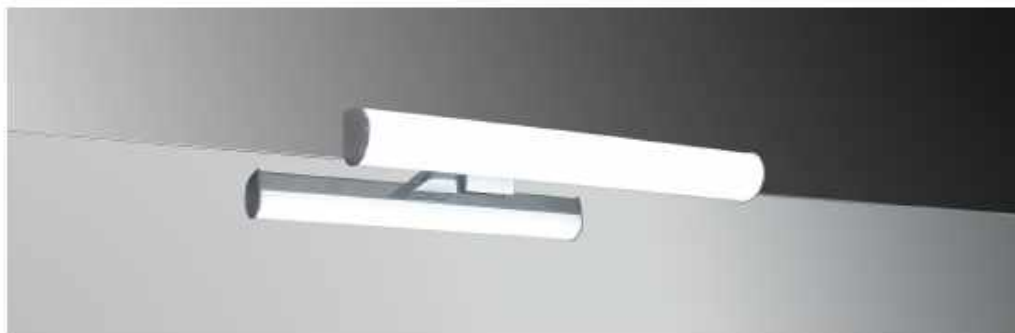

Drop 45 cm



Drop 60 cm



Drop LED

MEDIDAS	WATIOS LED	LUMENS
30cm	7	600
45cm	7	650
60cm	14	1300

Acabados/finishes:
Cromo / Chrome

Doble sistema de fijación / Dual fixation system

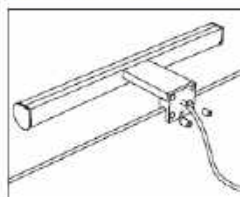

Espejo
Mirror

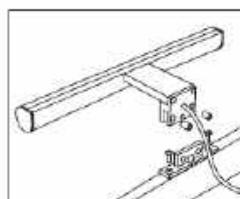

Marco
Frame

Ficha técnica / Data sheet



Round 30 cm



Round 45 cm



Round 60 cm



Round LED

MEDIDAS	WATIOS LED	LUMENS
30cm	7	600
45cm	7	650
60cm	14	1300

Acabados/finishes:
Cromo / Chrome

Ficha técnica / Data sheet



Doble sistema de fijación / Dual fixation system

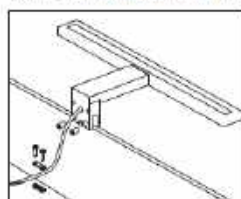

Espejo
Mirror

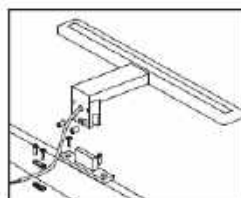

Marco
Frame

MAMPARAS ESPECIALES A MEDIDA (CONTRACT).

spaziali

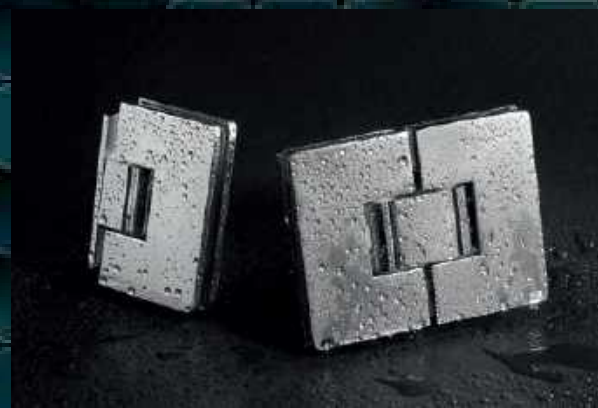

MAMPARAS ESPECIALES A MEDIDA (CONTRACT).

EN LOS ÚLTIMOS AÑOS, EL CUARTO DE BAÑO HA COBRADO UN GRAN PROTAGONISMO DENTRO DEL HOGAR PASANDO A SER OBJETO DE LAS REFORMAS MÁS IMPORTANTES Y CENTRO DE LAS MIRADAS DE INTERIORISTAS Y DECORADORES. CON ESTA EVOLUCIÓN, LAS MAMPARAS DE BAÑO HAN PASADO A SER PARTE IMPORTANTE DE DICHO ESTILO Y DECORACIÓN Y, POR TANTO, HAN ABIERTO UN MUNDO DE POSIBILIDADES DECORATIVAS EN EL BAÑO.

PARA QUE ESA MULTITUD DE POSIBILIDADES PUEDA HACERSE REALIDAD, DANDO LUGAR A DIFERENTES ESTILOS DECORATIVOS SON IMPRESCINDIBLES LAS MAMPARAS DE BAÑO A MEDIDA.

COMO REFERENTE EN MAMPARAS DE BAÑO DE DISEÑO, EN SPAZIA DISPONEMOS DE UN AMPLIO CATÁLOGO COMPUESTO POR MAMPARAS DE DUCHA ABATIBLES, MAMPARAS CON PUERTAS CORREDERAS, MAMPARAS PLEGABLES Y MUCHAS MÁS CON EL FIN DE PARTICIPAR EN LA DECORACIÓN Y PERSONALIZACIÓN DE SU HOGAR SEGÚN SUS NECESIDADES Y GUSTOS.

LA IMPRESIÓN DIGITAL SOBRE VIDRIO DE NUESTRAS MAMPARAS DE BAÑO A MEDIDA PERMITE ADAPTAR NUESTROS MODELOS A LAS ÚLTIMAS TENDENCIAS EN DECORACIÓN DE BAÑOS CONSIGUIENDO CON ELLO BAÑOS MODERNOS, BAÑOS CLÁSICOS O BAÑOS DE ESTILO INDUSTRIAL ENTRE MUCHOS OTROS EJEMPLOS.

LAS MAMPARAS DE BAÑO A MEDIDA SPAZIA DISPONEN DEL ACABADO ESPECIAL ANTICAL POR AMBOS LADOS EN TODOS LOS MODELOS, QUE ASEGURA SU FÁCIL MANTENIMIENTO Y PERMITE CONSERVARLAS EN PERFECTO ESTADO DURANTE MÁS TIEMPO.



EMPRESA

SPAZIA es una empresa especializada en el diseño y fabricación de mamparas de baño a medida y puertas correderas. Nace con la premisa de ajustarse a las demandas del mercado con el único objetivo de ofrecer un servicio personalizado que se adapte a los requerimientos específicos de nuestros clientes.

Para ello buscamos la solución más adecuada a cada una de las diversas situaciones que se pueden presentar en nuestros hogares y baños.

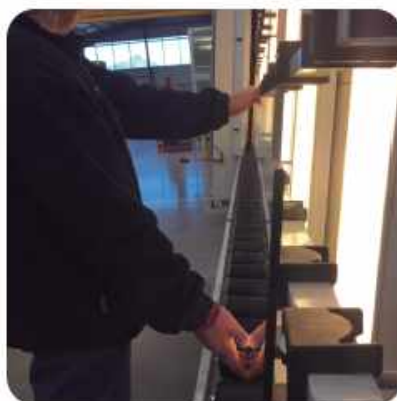

PRODUCTO

Las innovadoras técnicas de SPAZIA, son la base del desarrollo de una gama de productos que evoluciona y mejora constantemente; gracias entre otras cosas, al trabajo de un grupo de profesionales, que se preocupan por el diseño, la investigación, la fiabilidad, la funcionalidad, y el servicio especializado. Estos son los puntos cardinales de la estrategia y la acción de SPAZIA, lo que permite que nuestros clientes puedan disfrutar de una amplísima gama de productos con una calidad inmejorable.



CALIDAD

Todos los elementos de nuestros productos cumplen los más altos estándares de calidad en cuanto a especificaciones técnicas y seguridad se refiere.

Los cristales usados cumplen la normativa que certifica la máxima calidad a los requerimientos de ensayos. Asimismo, todos los perfiles y aleaciones poseen tratamientos anticorrosión para lograr la máxima resistencia y durabilidad.

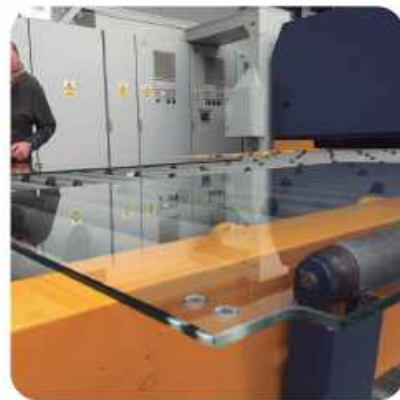

COMPROMISO

En SPAZIA sabemos que el servicio y asesoramiento son la base fundamental para lograr que el producto llegue a su hogar en las mejores condiciones, y sea instalado de una forma apropiada.

Para ello contamos con una red profesional que le asesorarán sobre su correcto uso con el fin de que el producto sea más duradero.



AIDIMA
INSTITUTO TECNOLÓGICO



NATURE

Características

- Altura estándar de **1950 mm**
- Tratamiento anticifra a dos caras
- Perfilos laterales de sujeción de tipo en U en aluminio: brillo o negro anodizado
- Componentes de la barra de refuerzo: en acabado: brillo o negro mate
- Vidrio templado de **6mm / 8mm** de espesor según normativa UNE-EN 14428.
- Marcado CE con normativa EN 12150-1
- Fabricado en España





MOON

Características

- Altura de 1950 mm con posibilidad de bajar hasta 2200 mm
- Testeado según EN 12543
- Celo superior de aluminio acabado como brisa, negro mate, o blanco mate
- Perfilas de aluminio de soporte de tipo en U de aluminio tipo brisa, negro mate, o blanco mate
- Perfilas con rodillos en el punto de apoyo
- Perfilas con bloqueo de punto
- Perfilas de seguridad integrada
- Estándar europeo con posibilidad de abajar la altura en otros países
- Codo de aluminio acabado como brisa, negro mate, o blanco mate
- Vaso negro en aluminio tipo brisa, negro mate, o blanco mate
- Vaso templado de 6mm de espesor según normativa UNE EN 1882
- Aluminio CE con normativa EN 12543
- Posibilidad de poner cualquier tipo de vidrio y hacer diferentes decoraciones
- Fabricado en España

Acabado de la perfilera



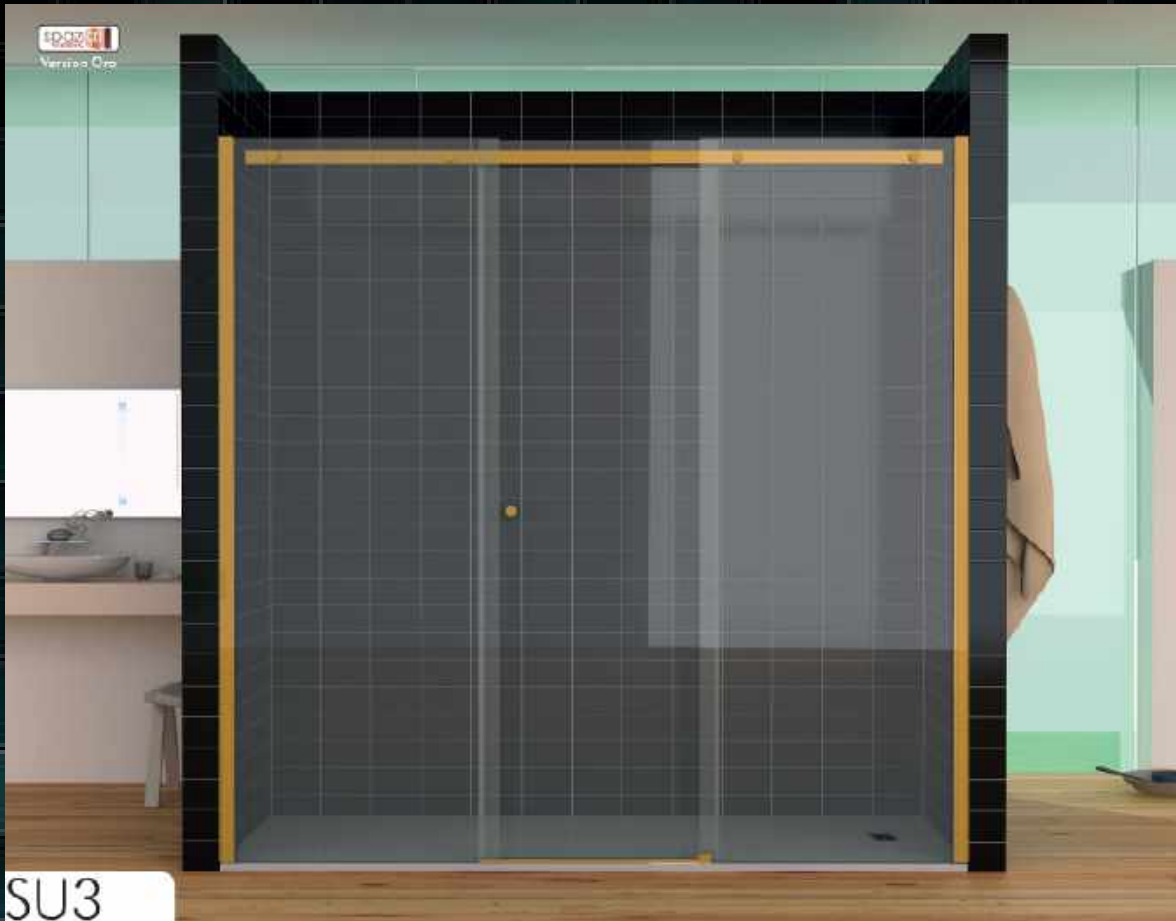

EDUZ
Versione Cap

SUITE

SU3



SUITE

U4A



PS4AT



• Perfil a pared cromo brillo



• Cierre magnético a pared



• Guiador metálico

PASS

Características

- Altura de **1950 mm**
- Tratamiento antiata a dos caras
- Guía superior de aluminio anodizado cromo brillo
- Perfilas laterales de aluminio de tipo en U de aluminio cromo brillo
- Puertas con rodamientos ajustados en altura
- Uñas que permiten el cruce entre puertas
- Freno con topes de goma
- Junta de estanqueidad incorporada
- Guiador inferior cromado cromo brillo
- Vete agrietar en aluminio cromo brillo
- Vidrio templado de **6mm** de espesor según normativa UNEEN 14428
- Marco de CS con normativa EN 12150-1
- Fabricado en España



PS3T

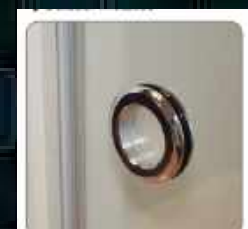

• Uñero metálico



• Rueditas regulables



• Soporte a pared de la guía



DN2



• Pomo metálico

• Ruedas regulables

• Soporte a pared de la guía

DUNE

Características

- Área interior de 1500 mm exterior de 2000 mm
- Vidrio templado de 8 mm
- Perfil en acero inoxidable satinado, 40x40 mm
- Perfil en aluminio de 40x40 mm con el mismo acabado
- Puerta con mecanismo de cierre magnético al abrir
- Mecanismo tipo de guía
- Perfil de aluminio pintado
- Cierres y tiradores en acero inoxidable
- Perfil negro de acero (no disponible)
- Cierres de perfil en aluminio de diferentes acabados de la colección **SPAZIA COLOR** con el precio de 15.000€ (aprox.)
- Vidrio templado de **8 mm** de espesor según normativa UNE EN 12150
- Modelo: 23. Serie: DUNE (12150)
- Referencia al Explotar

Acabado de la perfilera



DN3

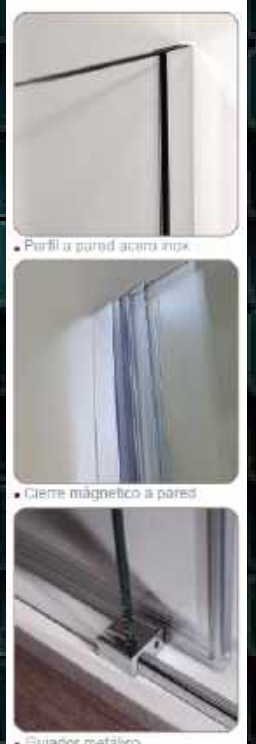

• Perfil a pared acero inox

• Cierre magnético a pares

• Guía metálica



DN3A

DUNE



DUNE

DN4U



FR3A



- Perfil a pared acero inox
- Cierre magnético a pared
- Rodador metálico

FORUM

Características

- Alta resistencia: 1950 mm altura x 2400 mm
- Tratamiento anticorrosión
- Queda patente de agua por un dispositivo con filtro y red
- Perfil superior de aluminio de 60 en 116 mm ancho
- Perfil con rebatimiento de 20 mm para el vidrio
- Perfil inferior de 20 mm
- Perfil con 100 de goma
- Perfil de aluminio con 116 mm ancho
- Dirección inferior verso: 100 mm ancho
- Vidrio templado de 8 mm de espesor según normativa NF 601 1423
- Modelo C2 con altura de 1950 mm
- Fabricado en España

Accesorios de la perfilada [C. 0001](#) [C. 0002](#)



FR4



- Tirador metálico
- Soporte vidrio - guía
- Ruedas regulables



FORUM

FR4U



FORUM

FR3



NEXUS

NX3AM

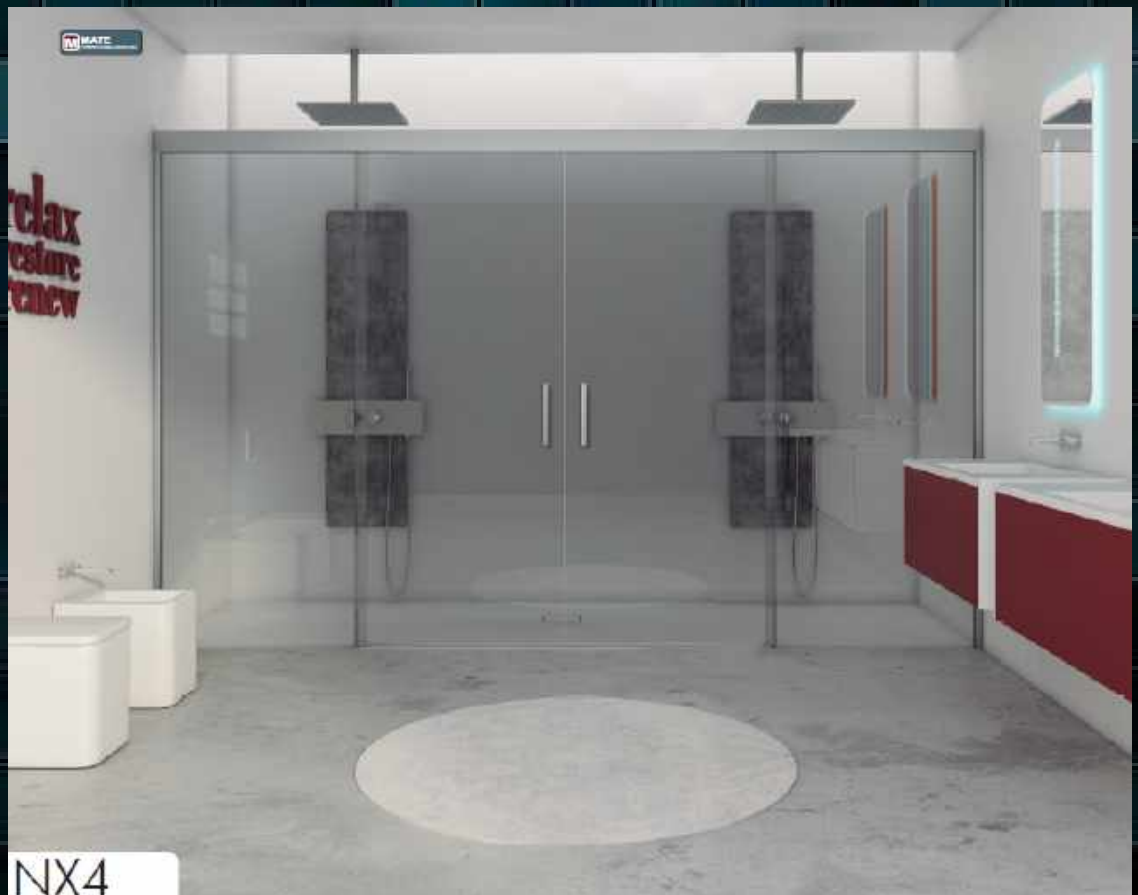

NEXUS

NX4



IN3A



• Tirador metálico



• Esquinero superior de la guía



• Soporte de guía a pared

INFINITI

Características

- Alta resistencia 2000 mm resistencia hasta 3400 mm
- Seguridad control y libre control
- Cierre superior de aluminio anodizado
- Soportes laterales de aluminio anodizado de 12 de aluminio plateado
- Soportes con juntas de goma: protección al agua
- Perfilado metálico anodizado
- Juntas selladas: resistencia al agua, al frío, al calor
- Perfil de aluminio anodizado
- Cierre superior: protección al agua
- Juntas laterales: protección al agua
- Perfilado de aluminio anodizado
- Soportes de aluminio anodizado
- Soportes de aluminio anodizado
- Soportes de aluminio anodizado
- Soportes de aluminio anodizado

Análisis de la periferia



IN4



• Perfil a pared platea brillo



• Cierre magnético a pared



• Gelador de policarbonato



RL3A



• Soporte a pared cromo brillo



• Cierre magnético a pared



• Guidador superior metálico

ROLLING

Características

- Dimensiones: 1100 mm anchura x 2000 mm
- Espesores: vidrio 6 mm, aluminio 2,0 mm
- Perfil: aluminio de alta resistencia anodizado
- Acabado: brillo o mate
- Opción de alfombrilla integrada
- Incluye un juego de grifería completa y fregadero
- Juego de accesorios (cepillo) incluido
- Vitrófono integrado de 1000 mm ancho (opcional)
- Montaje: 20 min montaje, 10 min fijar
- Instalación en 1 hora

Ambiente de la pantalla:



RL2V



• Uñero metálico



• Rueda inferior en negro mate



• Guía a pared



CC4S



• Brazo de refuerzo en negro



• Perfil lateral en aluminio brillo



• Bisagras en acero

COMBI

Características

- Serie modelo de 2400 mm - anchura 2400 mm
- Dimensiones total a piso: 2400 mm
- Cierre de la puerta lateral con puerta completa o puerta batiente
- Cables con anillos de 45 mm con 4 cables, o de 50 mm con seis cables distribuidos
- Frenos y amortiguadores silenciosos de alta, media o baja velocidad
- Disponibilidad de dos partes de la misma profundidad para el vidrio
- Soporte de vidrio con el protector
- Viteo integrado de **Black** de espesor según anchura (14-17-18-22)
- Material: CC con acabado (R12) (20)
- Fabricación: España

Anchura de la puerta: Batiente Lateral



CC4W



• Guía metálica



• Guía superior de aluminio



• Tirador metálico

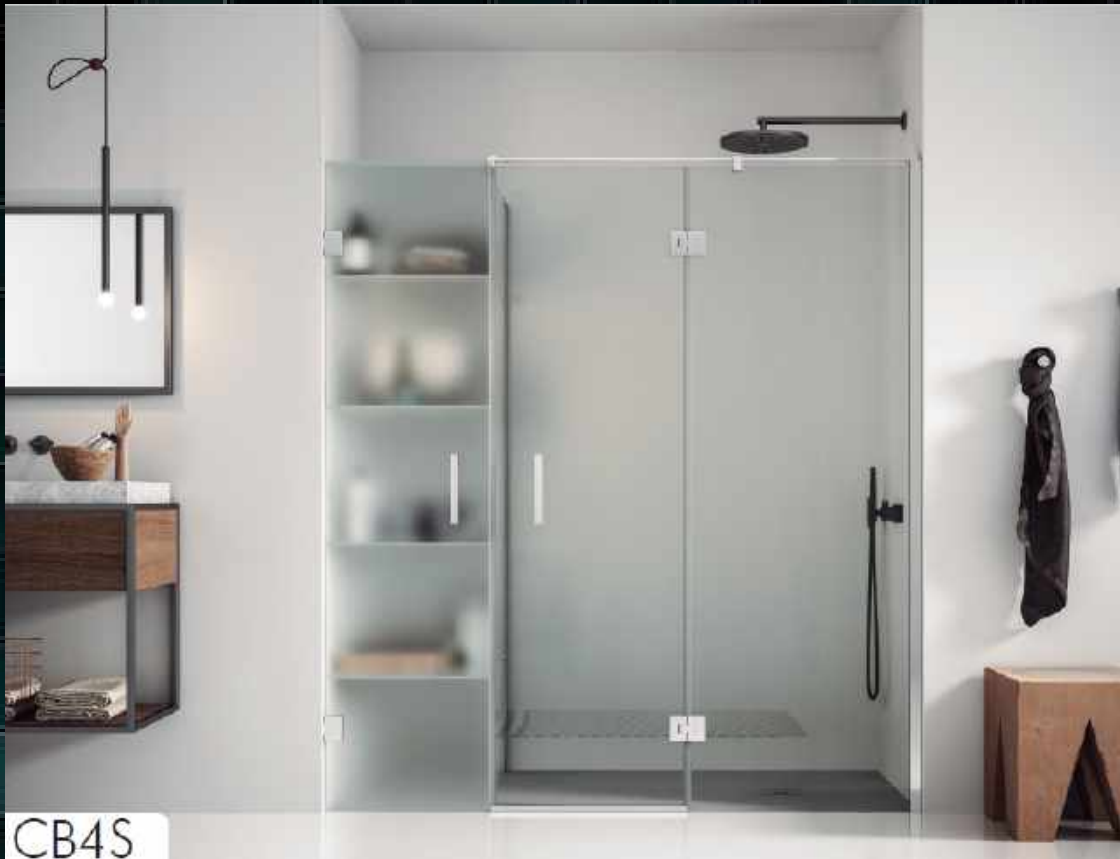

CB4S

COMBI

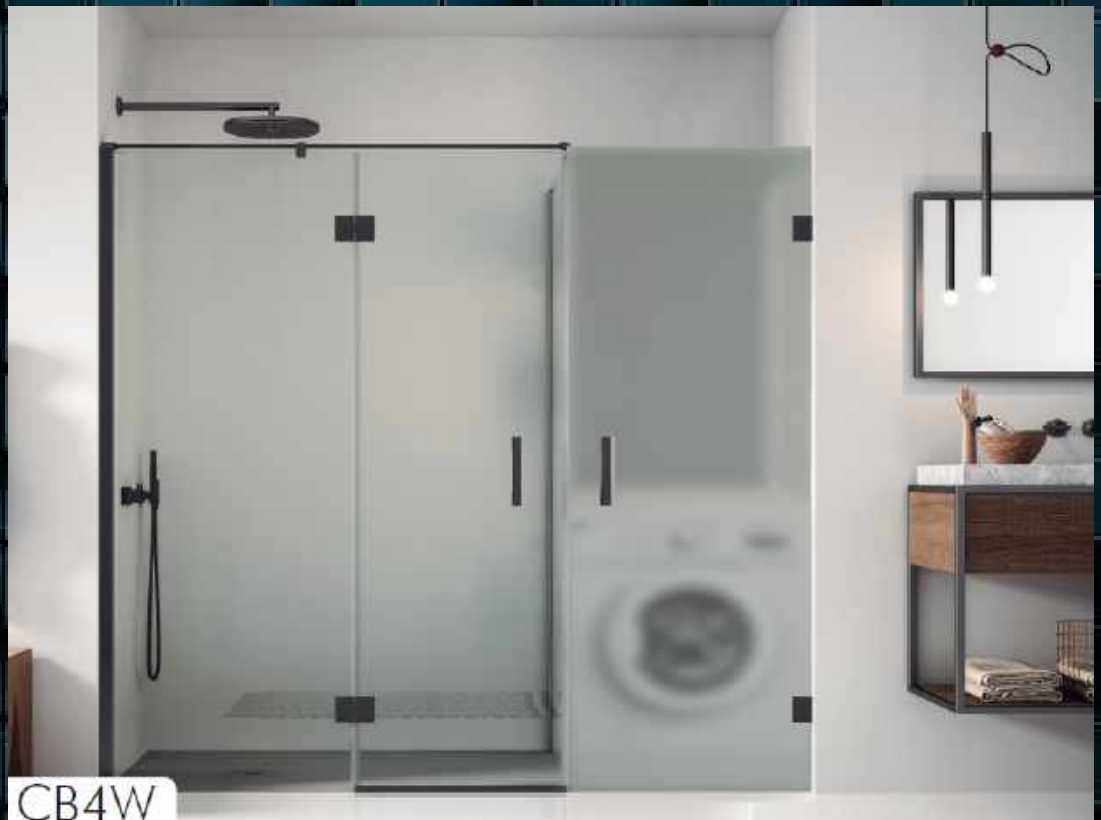

CB4W

COMBI



STAR



ST2



STAR

ST2P



ST3PF

STAR



STAR

ST3AP





STAR

ST3



STAR

ST4A

HANDI

¿Necesita una Mampara de Baño para una Persona que Requiere Ayuda a la Hora de la Ducha? La serie de mamparas de ducha a medida Handi está especialmente diseñada para ello.

Dispone de varios modelos de mamparas de ducha Handi: dos o una puerta dividida en dos partes con apertura batiente que le ofrecen la posibilidad de abrir la parte superior de la mampara para, desde el exterior, poder ayudar a la persona que se encuentra en el interior de la ducha.

Es perfecta como mampara de ducha para niños. También como:

- Mampara de ducha para minusválidos
- Mampara de ducha para discapacitados
- Mampara de ducha para ancianos



HN2

Características

-  2 puertas batientes a 180°
-  Espesor vidrio 6mm
-  Tratamiento antical a dos caras
-  Altura 1950. Máxima 2100mm
-  Cierre magnético
-  Ancho máximo de puerta 900mm



HN4A

Características

-  4 puertas batientes a 180°
-  Espesor vidrio 6mm
-  Tratamiento antical a dos caras
-  Altura 1950. Máxima 2100mm
-  Cierre magnético
-  Ancho máximo de puerta 900mm

HANDI

¿Necesita una Mampara de Baño para una Persona que Requiere Ayuda a la Hora de la Ducha? La serie de mamparas de ducha a medida Handi está especialmente diseñada para ello.

Dispone de varios modelos de mamparas de ducha Handi: dos o una puerta dividida en dos partes con apertura batiente que le ofrecen la posibilidad de abrir la parte superior de la mampara para, desde el exterior, poder ayudar a la persona que se encuentra en el interior de la ducha.



Es perfecta como mampara de ducha para niños. También como:

- Mampara de ducha para minusválidos
- Mampara de ducha para discapacitados
- Mampara de ducha para ancianos



HN3

Características

-  1 fijo y 2 puertas batientes a 180°
-  Espesor vidrio 6mm
-  Tratamiento antical a dos caras
-  Altura 1950. Máxima 2100mm
-  Cierre magnético
-  Ancho máximo de puerta 900mm



HN2A

Características

-  2 puertas batientes a 180°
-  Espesor vidrio 6mm
-  Tratamiento antical a dos caras
-  Altura 1950. Máxima 2100mm
-  Cierre magnético
-  Ancho máximo de puerta 900mm



NOVA

NV3A



NOVA

NV3AR

NOVA



NV3AFL



NV4A

NOVA

NOVA



NOVA



NOVA

NV2A



NOVA

NV2R



90012

NOVA

NV2AM



Decorado tipo 3

NOVA

NV4



QD1



- Perfil lateral en aluminio brillo
- Bisagra entre vidrios
- Barra superior a vidrio

QUADRO

Características

- Alta calidad de 1920 mm, con posibilidad de hasta 2200 mm
- Frenando orbital a 360 grados
- Perfil lateral de aluminio de 50 mm de ancho con efecto espejo o negro mate
- Componente de la base de aluminio anodizado con efecto espejo o negro mate
- Bisagra con espesor QD1 para si el usuario necesita un tamaño bello o negro mate
- Juntas de estanqueidad montadas al suelo
- Trazo de perfilado con acabado brillo o negro mate
- Verticales metálicas en aluminio brillo o negro mate
- Vidrio templado de 8 mm y 6 mm de espesor según necesidad (REC11423)
- Aluminio CE con acabado EN 121011
- Fabricado en España

Acabado de la periferia BRILLO NEGRO



QD2A



- Tirador metálico cromo brillo
- Soporte barra a pared
- Tirador metálico negro

QUADRO



QD2F



QD2AR

QUADRO

QUADRO



QD3A



QUADRO



NT01



• Brazo largo de refuerzo

• Soporte de brazo a pared

• Soporte de suelo a techo

NATURE

Características

- Alta resistencia de 1900 mm, con anchura de hasta 2000 mm
- Acabados en aluminio satinado
- Perfil de aluminio de espesor de 1,5 mm (1,5 de aluminio)
- Resistencia de tracción superior a 1000 kg/cm²
- Resistencia de tracción superior a 1000 kg/cm²
- Resistencia de tracción superior a 1000 kg/cm²
- Resistencia de tracción superior a 1000 kg/cm²
- Resistencia de tracción superior a 1000 kg/cm²
- Resistencia de tracción superior a 1000 kg/cm²
- Resistencia de tracción superior a 1000 kg/cm²

Acabado de la periferia



• Perfil aluminio alto brillo

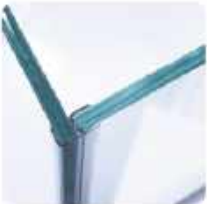

• Junta de 90° de policarbonato



• Perfil perimetral a suelo y techo para modelo NT00

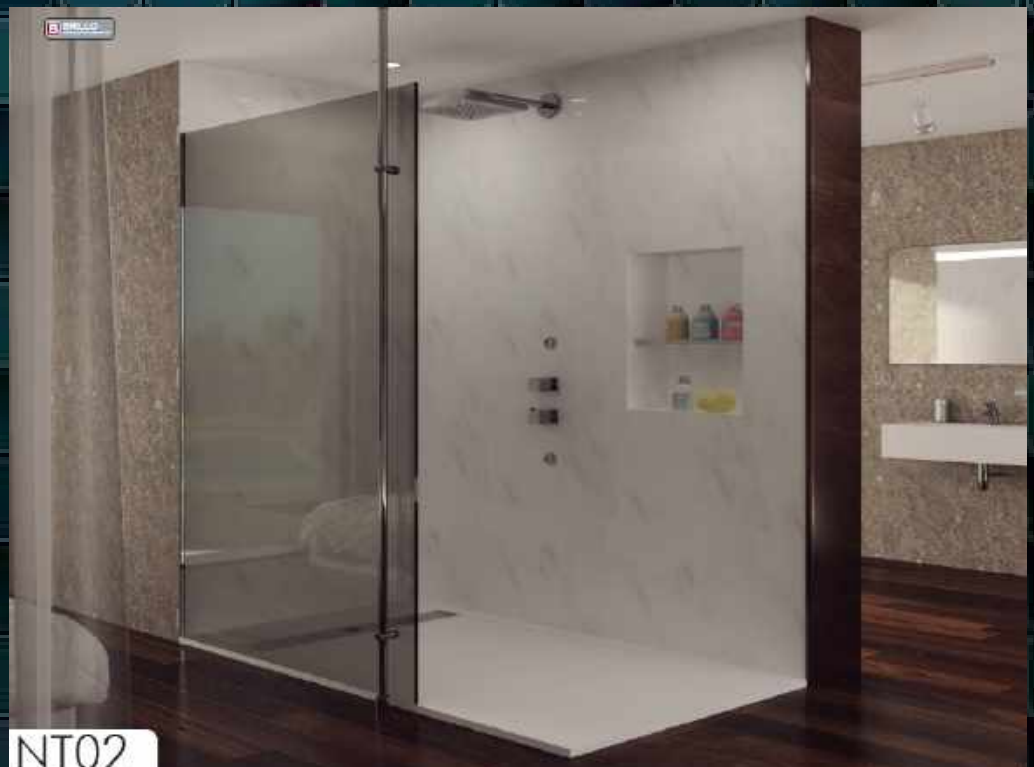

NT02

NATURE



NT02H



NT06

NATURE



NATURE

NT00



NATURE

NT04

BARRA LUX Adaptable a todas las series



BARRA LUX



Rango de medida de la barra	MATE
Hasta - 90	275
90 - 120	295

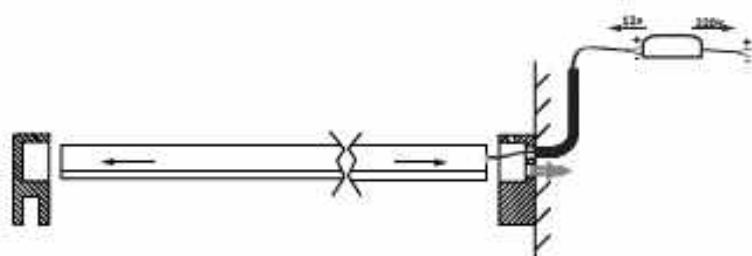

Características

Barra con luz en aluminio anodizado mate.
 Soporte a pared regulable con prisioneros de ajuste y embellecedor para ocultar el cable.
 Soporte a vidrio regulable con prisioneros de regulación para mamparas de 6 mm y 8 mm.
 Tubo refuerzo Lux con Luminaria de 15W/m, con sellado Epoxi para total estanqueidad frente al agua, según normativa IP66.
 Soporte válido para cualquier modelo de mampara.
 Producto fabricado a medida en aluminio anodizado mate.

TOMA DE MEDIDAS

Indicar la anchura del plato o distancia entre vidrio y pared.
 Para colocación en obra nueva, dejar una salida de tubo corrugado a 1980 mm de altura.
 Para colocación en obra ya ejecutada, subir el cableado hasta el techo con canaleta adhesiva.



Barra soporte con luz



Pinza fijación a vidrio



Fijación a pared



BARRA LUX





PF1



• Soporte a pared del brazo



• Posibilidad de pedir vidrios con impresión digital



• Posibilidad de pedir vidrios con impresión digital

PROFILE

Características

- Alto estándar de 1910 mm, con anchura de 842 o 920 mm.
- Perfilado 24 mm de anchura con un espesor de 24x21 mm.
- Perfilado diseñado de acuerdo al tipo de la cámara utilizada para el vidrio.
- Posibilidad de realizar vidrios de diferentes espesores (10, 12, 15, 18 y 20 mm).
- Posibilidad de realizar vidrios con impresión digital en el momento de pedir.
- Camarero de la línea de vidrios en negro mate.
- Vidrio estándar de **Blak Line** en el primer vidrio estándar (200x114x8).
- Vidrio de 20 mm estándar (10-18).
- Vidrio de 12 mm.

Reservados todos los derechos.



PF2



• Detalle superior



• Detalle interior



• Unión central entre varios vidrios



BLAK LINE

PROFILE

PF2V



BLAK LINE

PROFILE

PF3

Decorados

Impresión digital

Spazia ofrece una amplia gama de productos impresos en vidrio de pequeño y gran formato,

Para Spazia imprimir sobre vidrio y posteriormente templar no tiene ninguna dificultad ya que estamos provistos de la maquinaria más sofisticada que existe hoy en día en el mercado.

Las pinturas usadas en el proceso de impresión se ofrecen como sistemas de piroado mono o bicomponentes y generalmente pueden ser aplicados al vidrio en líneas de continuo de hasta 7cm, a través de los 8 cabezales de impresión.

Normalmente un ciclo de 150° de curado es suficiente para secar la pintura; Posteriormente es introducido en el horno de templar donde se fusiona con la superficie del vidrio soporte, creando una unión inalterable y con una dureza sin igual a las ralladuras.

Gracias a un software de última generación se puede controlar el espesor que se requiere para dar mayor o menor transparencia.

Se pueden obtener los resultados deseados en espesor, dureza, color y apariencia, ajustando los parámetros del proceso de producción.

Con el fin de obtener los mejores resultados, tanto en hornos estáticos como continuos, es necesario ajustar el tiempo y la temperatura en concordancia con el peso y las dimensiones del producto a decorar.

Los productos resultantes cuentan con un certificado de calidad de fabricación otorgado por Spazia que garantiza la calidad del producto terminado y del proceso productivo de los mismos.



DECORADOS (SIMIL MATE)



TIPO 1



TIPO 2



TIPO 3



TIPO 7



TIPO 8



TIPO 9



TIPO 13



TIPO 16



TIPO 17

TAMAÑO DE IMPRESION

OPCION A

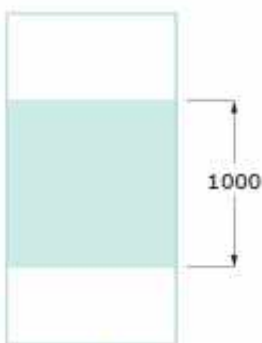

OPCION B

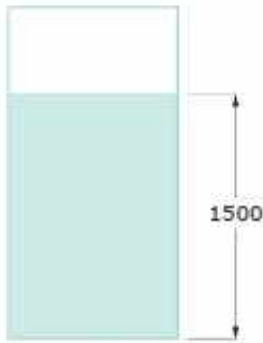

OPCION C

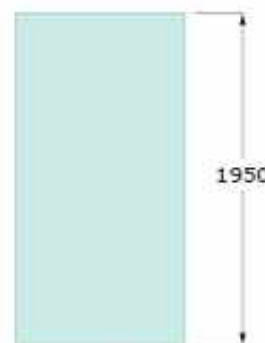

OPCION D

Cualquier diseño elegido por el cliente

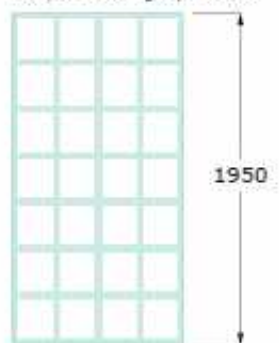



TIPO 4



TIPO 5



TIPO 6



TIPO 10



TIPO 11



TIPO 12



TIPO 18



TIPO 19



TIPO 20

DECORADOS (EN COLORES ESPECIALES)



TIPO 50



TIPO 51



TIPO 52



TIPO 53



TIPO 54



TIPO 55



TIPO 56



TIPO 59



TIPO 60

TAMAÑO DE IMPRESION

OPCIÓN D

Cualquier diseño elegido por el cliente

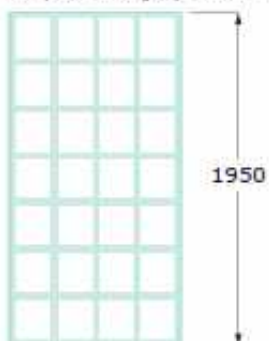

DECORADOS (CON IMÁGENES PERSONALIZADAS)

SPAZIA ofrece la posibilidad de realizar impresiones personalizadas en el vidrio con cualquier imagen que nuestros clientes deseen. Para ello nos conformamos con ofrecer unas pocas imágenes en este catálogo, ya que somos conscientes de que nuestros clientes tienen gustos muy variados. Por ese motivo, ofrecemos la posibilidad de elegir entre más de un millón de imágenes para acoplarla a su mampara o puerta de paso. Para ello hemos creado un acuerdo marco entre SPAZIA y el banco de imágenes 123RF, donde cada cliente podrá buscar la imagen que más se le acople a su personalidad e indicarnos su número de referencia.

Spazia se encargará de adquirir la imagen a la resolución adecuada e imprimirla en el vidrio con su sistema de impresión templable, de forma que sea inalterable en el tiempo.

Pasos a seguir:

- 1º Entra en nuestra web: <https://spazia.net/> y accede a la sección de decorados.
- 2º Selecciona el link imágenes personalizadas.
- 3º Accederás al banco de imágenes de 123RF y podrás buscar el tema que desees en la barra de búsqueda:



- 4º Obtendrás miles de resultados y podrás elegir al que más te guste.



- 5º Una vez elegida la imagen, indicamos el número de identificador de la imagen

Foto de archivo - Sakura



Identificador de la imagen : 11231795
Tipo de medios : Foto de archivo
Derecho de autor : 123RF (Añadir a favoritos)

- 6º Finalmente, nosotros nos encargaremos de plasmar la imagen en tu mampara



spaziati
wellness spaces.

FUSION

Mamparas divisorias de estancias



¿Que es FUSION ?

Fusion es un proyecto modular desarrollado íntegramente por SPAZIA para crear estancias mediante divisorias.

Surge con la idea de dividir zonas para crear ambientes delimitados, jugando con la luz y las transparencias del cristal.

El nombre de la serie "Fusion" se debe a su composición, ya que toda la estructura esta creada por módulos de medidas 80 x120 y 40x120 que se fusionan entre ellos para crear paneles de grandes dimensiones.

Todos los módulos que componen el panel, tienen la capacidad de unirse entre si, dando la posibilidad de generar múltiples combinaciones, adaptándose a cualquier estancia de nuestro hogar, oficina, comercio o zona común.

Para poder hacer montajes de suelo a techo se tienen que ir modulando las piezas de 120,80 y 40 cm;

Finalmente para completar la medida hasta el techo fabricamos un módulo a medida que completa la instalación.

En el caso de que no sea posible acoplar un módulo a medida, adaptamos una barra de sujeción hasta el techo en forma de brazo de refuerzo, de esta manera la apariencia es de un módulo totalmente a medida.

La estructura está realizada con periferia de aluminio con acabado anodizado en negro.

También se le puede dar un acabado personalizado con cualquier color de nuestra gama SPAZIA COLORS.

Su composición es totalmente versátil y configurable pudiendo crear más de 350 módulos diferentes.

Y todo ello gracias a la posibilidad de poder escoger diferentes acabados de vidrio para cada uno de sus módulos o de las partes que lo forman.

Pese a que el conjunto final sea de gran dimensión, su principal atributo es la ventaja de su modularidad, por ello, tanto el transporte hasta el lugar de colocación como la descarga, no conllevan ningún tipo de elementos adicionales ni costes inesperados.

Por ella, una sola persona pueda llevar a cabo todo el montaje con el consiguiente ahorro en la instalación.

El montaje es simple y sencillo para cualquier montador o incluso para el usuario particular, sin que sea necesario tener habilidades extraordinarias.





Unión entre cuadrantes



Perifería de contorno de los módulos



Unión a pared de los módulos







INFINITAS COMBINACIONES :

La variedad de módulos y la diversidad de tipos de vidrios hacen que la serie FUSION sea una solución idónea para dar al cliente un sin fin de posibilidades a la hora de hacer sus composiciones.

Incluso una vez presentados los módulos en el lugar de montaje, puede modificarse su posición para generar más opciones de colocación.



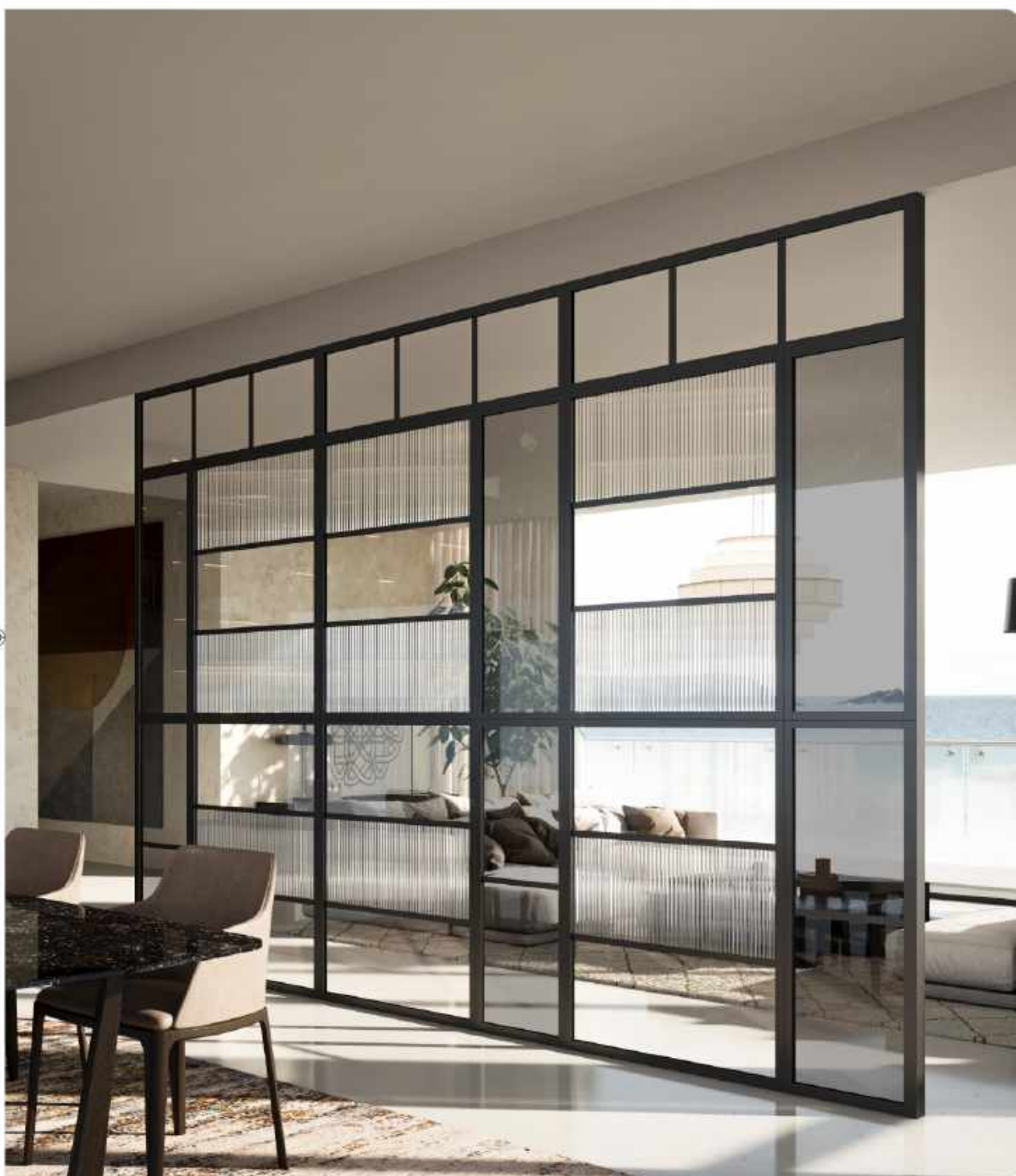

FACILIDAD DE MONTAJE :

La instalación en los hogares es sencilla. Todos los paneles son ligeros de transportar, fáciles de montar, sencillos de combinar y no se necesita manipular ninguna pieza para culminar el montaje ya que llegan mecanizados a la medida justa.





SOLUCIÓN RÁPIDA Y LIMPIA :

Gracias a su limpieza y rapidez de montaje, la serie FUSION se puede instalar en zonas de oficina sin tener que deshabilitar la zona de trabajo.

Pese al gran tamaño del conjunto, los módulos sueltos pueden transportarse fácilmente para facilitar tanto su recepción como su ubicación final en el lugar de montaje sin tener que prever elementos adicionales de elevación.





EJEMPLOS DE COLOCACIÓN

Colocación sobre muretes, pared y techo

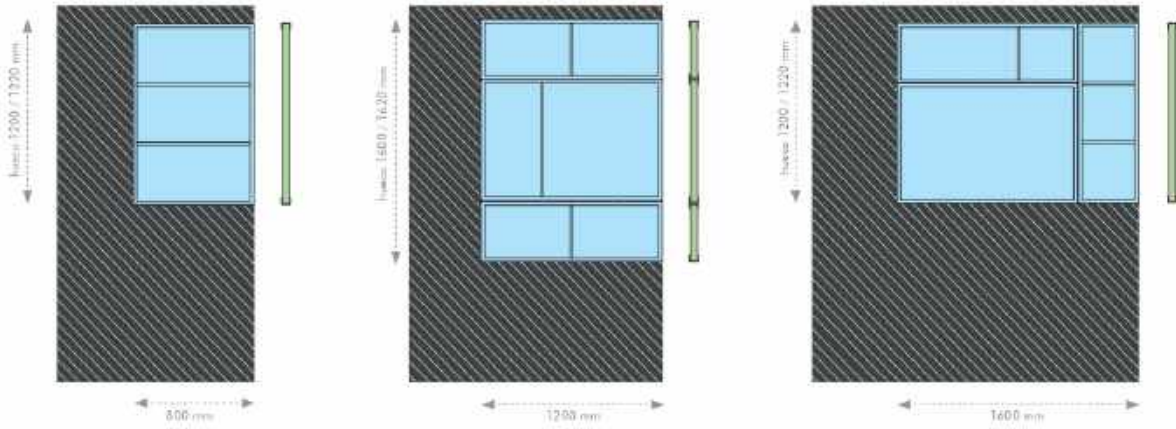

Colocación sobre muretes y techos

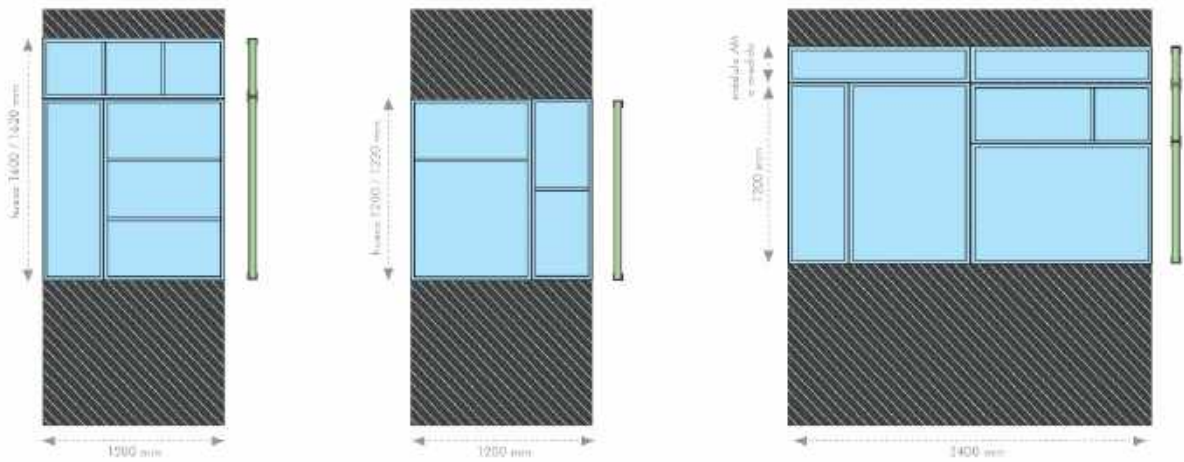

Colocación sobre muretes a techos altos con brazo expansor

(longitud máxima del brazo 500 mm.)

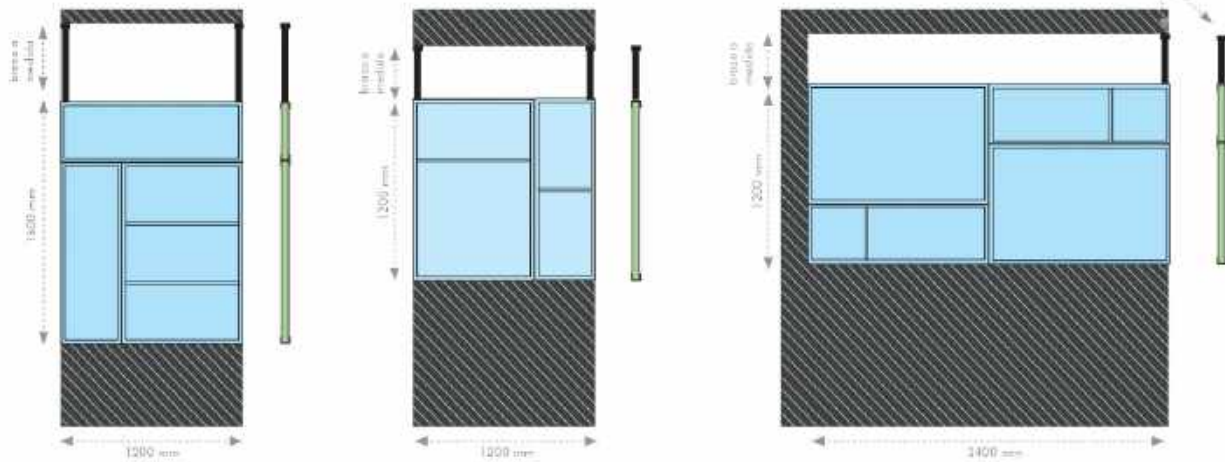



Colocación de suelo a techo y pared

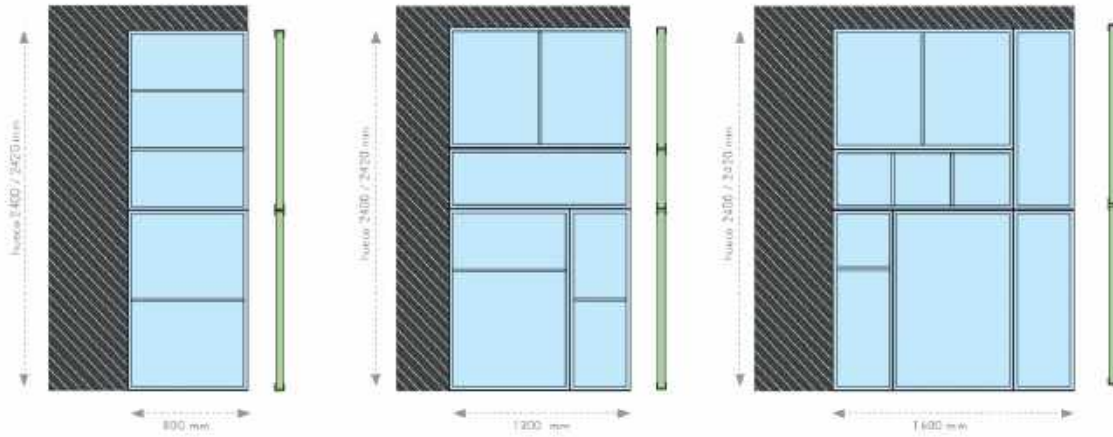

Colocación de suelo a techo

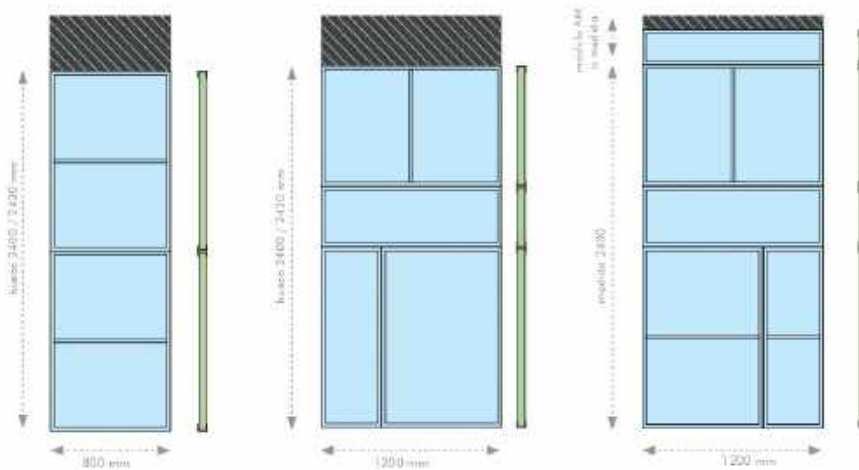

Colocación en línea

(Es necesario poner pilares intercalados de 60x40 mm en montajes en línea y su número dependerá de la altura del conjunto)

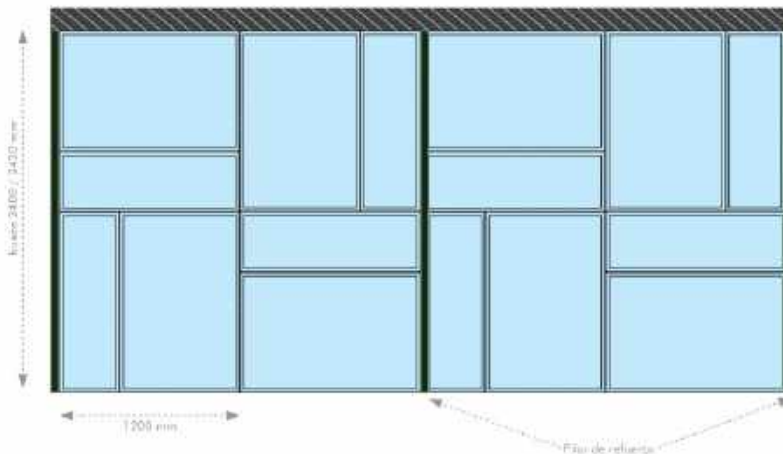



FU1N



Características

-  Puerta corredera.
-  Espesor de la puerta con manija 9 mm
-  Altura 2000. Máximo hasta 2420mm
-  Bovedas con ajuste vertical
-  Cierre amortiguado incluido
-  Ancho máximo de la puerta 1000 mm
-  Peso máximo soportado 120kg
-  Incremento de altura, cada 5cm +5%
-  Los vidrios superiores a 2200 de alto, tienen recargo de transporte, +120 € neto.

Rango de medida de la puerta	G0	G1	G2
	Transparente	Mate, Extraclear, Gris, Bronce	Acanalado, Carglass, Irroxiado
HASTA - 800			
801 - 1000	FUSION <small>by spazca</small>		
1001 - 1200			

Sección del conjunto

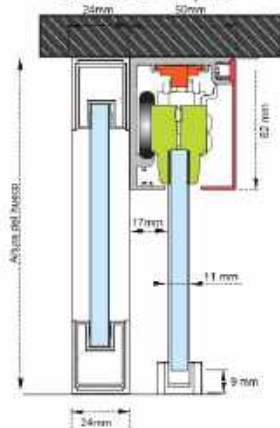

Detalle guío

Medidas máximas de la puerta

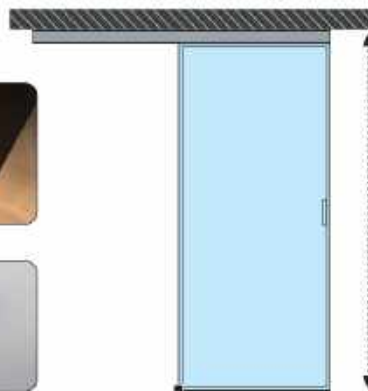

Ejemplo de colocación

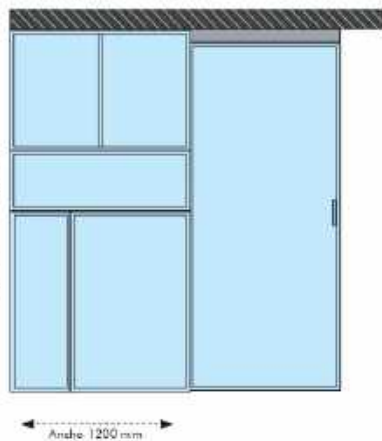







FUIS



Características

-  1 puerta abatible 180°
-  Espesor de la puerta con marco 9 mm
-  Altura máxima 2000
-  Ancho máximo de la puerta 900mm
-  Peso máximo soportado 45 kg

Rango de medida de la puerta	G0 Transparente	G1 Mata, Extradim, Gris, Blanco	G2 Acanalado, Carglass, Tramado
			
Hasta 700	FUSION <small>by SPOZZI</small>		
701 - 800			

Sección del conjunto

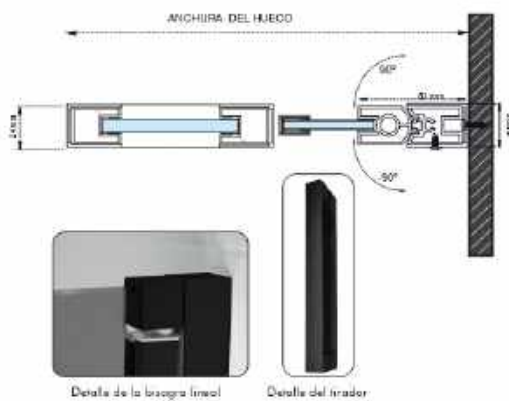

Medidas máxima de la puerta



Ejemplo de colocación

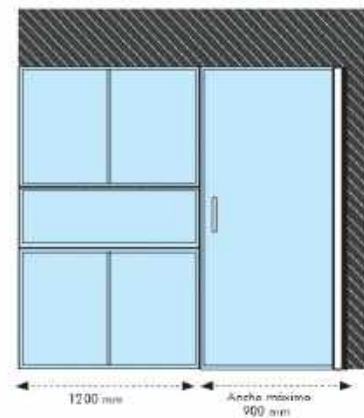







FUIP



Características

-  1 puerta abatible 180° con tirador. Opcional con maneta magnética FUCM.
-  Espesor de la puerta con marco 11 mm.
-  Altura máxima 2000.
-  Ancho máximo de la puerta 800mm.
-  Peso máximo soportado 45 kg.

Rango de medida de la puerta	G0 Transparente	G1 Mate, Extraduro, Gris, Bronce	G2 Acanalado, Carglass, tramado
Hasta 800			

Sección del conjunto

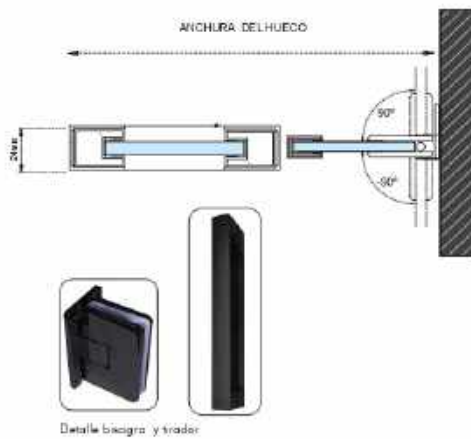

Medidas máxima de la puerta

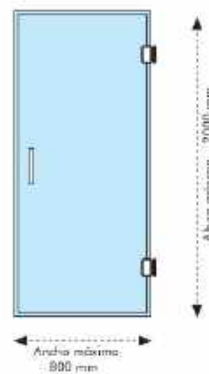

Ejemplo de colocación

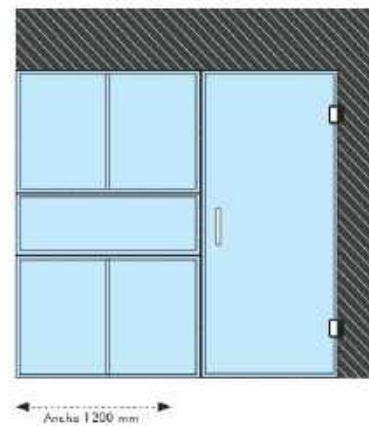



FUCM

Tirador con cerradero magnético

CERRADERO
MAGNETICO

BLACK LINE

CON LLAVE DE
SEGURIDAD

FUSION

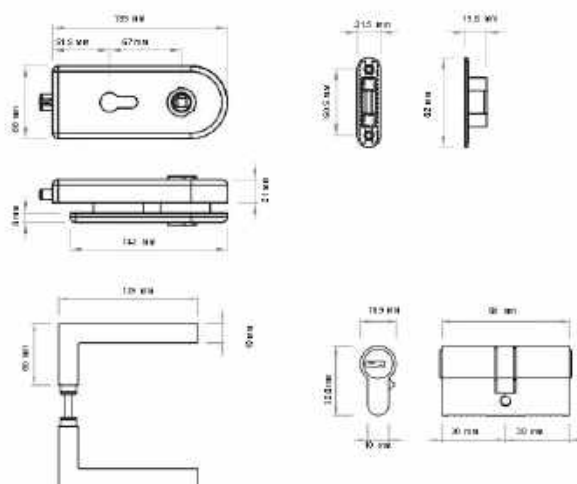

Módulos

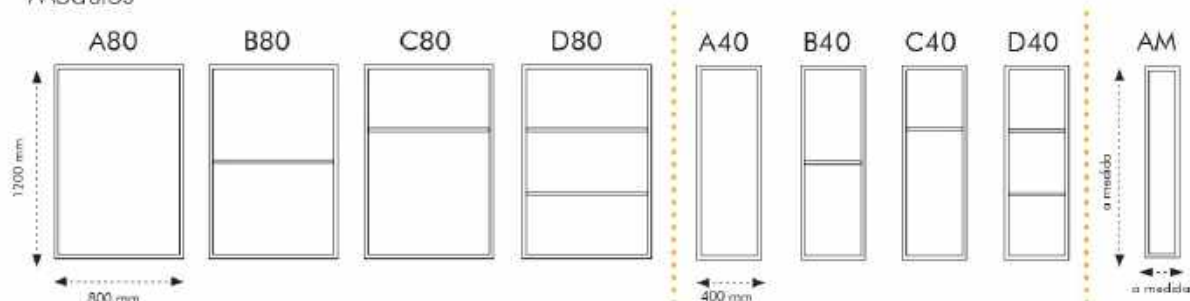

Módulo	Medida	Descripción	G0	G1	G2
	80x120	A80, B80, C80, D80			
	40x120	A40, B40, C40, D40			
	? x ? ? x ?	A media para ajuste a techo (lados menor o igual a 40 x120)			
	24x500	Soporte a techo mas brazo			
	40x60x3000	Pilar intercalado macizado			

GRUPO G0



TR Transparente

GRUPO G1



MA Mate - Ácido



PB Parsol Bronce



PG Parsol Gris

GRUPO G2



VA Vidrio acanalado



VC Vidrio carglass



VT Vidrio Tramado

PROPUESTA DE PEDIDO



FECHA: _____
 CLIENTE: _____
 DIRECCIÓN: _____
 REFERENCIA DE PEDIDO: _____
 TEL: _____ FAX: _____

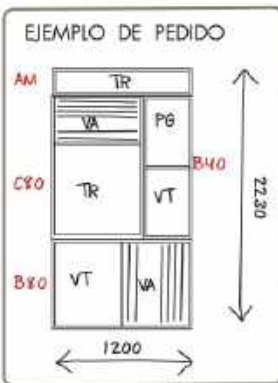
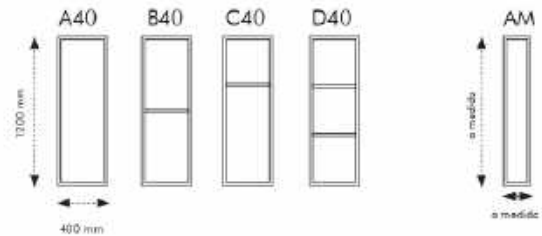
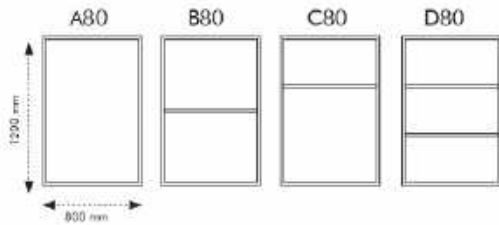

ACABADO DEL PERFIL

PLATA BRILLO
 NEGRO MATE

MEDIDAS TOTALES

ANCHO: _____
 ALTO: _____

CERRAMIENTO

DE SUELO A TECHO
 CON BRAZO A TECHO

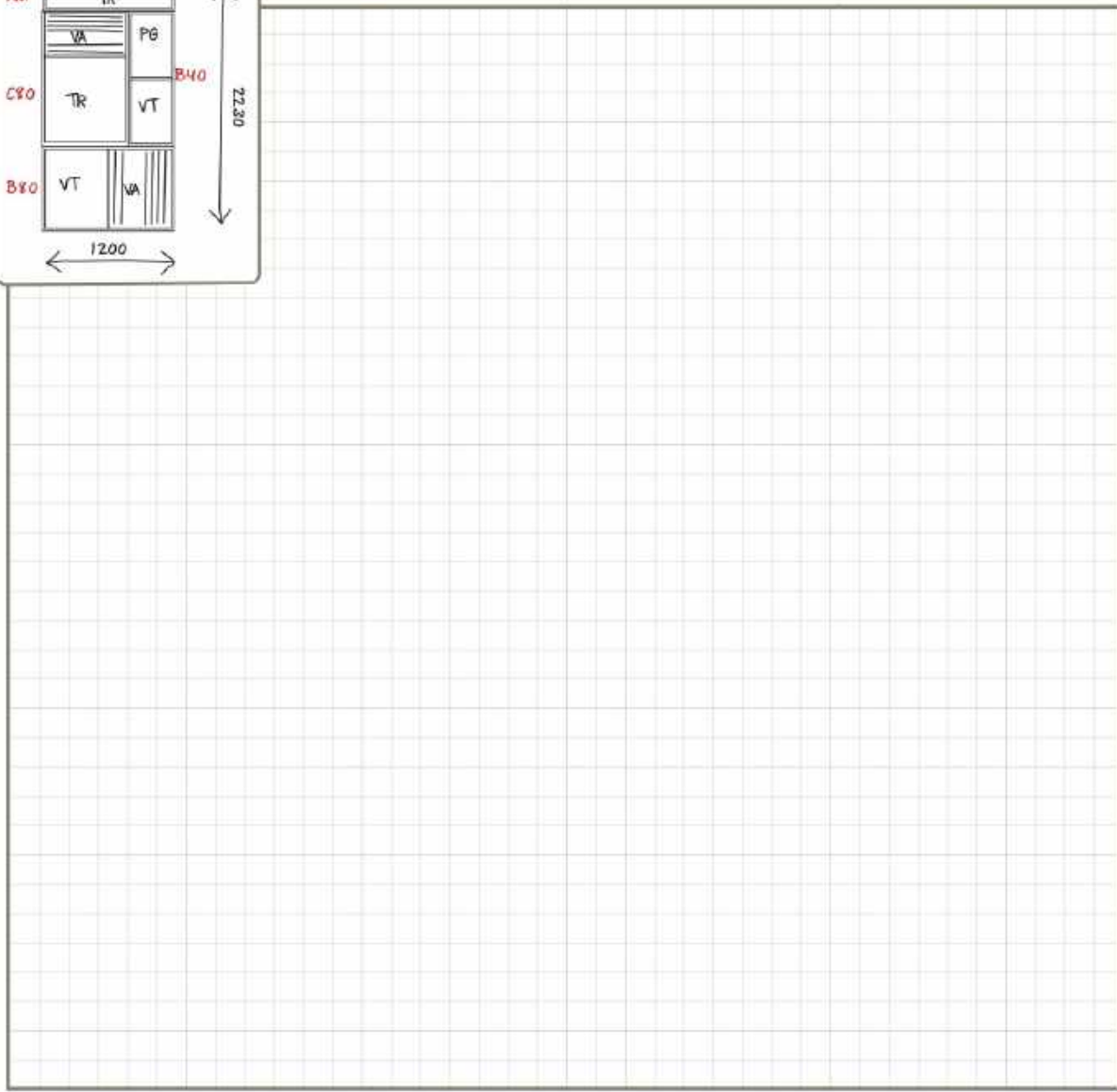

"DESEAMOS QUE ESTE CATÁLOGO HAYA SIDO DE SU AGRADO, NUESTRO OBJETIVO ES PODER OFRECER A NUESTROS CLIENTES SIEMPRE LOS PRODUCTOS MAS VANGUARDIastas CON LA MEJOR RELACIÓN CALIDAD/PRECIO DEL MERCADO CON EL MEJOR SERVICIO EXPRESS, ADEMÁS DE UN ASESORAMIENTO PERSONAL Y LA BUSQUEDA DE CUALQUIER ALTERNATIVA EXISTENTE PARA SATISFACER SUS NECESIDADES.

APROVECHAMOS PARA INDICARLE QUE EL NUMERO DE REFERENCIAS SON MUCHO MAYOR QUE LAS AQUÍ MENCIONADAS.

NUESTRO DEPARTAMENTO DE ESTUDIO LE FACILITARA UN PRESUPUESTO TOTALMENTE PERSONALIZADO PARA SU PROYECTO, ELIGIENDO SIEMPRE LOS ARTÍCULOS QUE MEJOR SE ADAPTEN A SU PROYECTO.

AGRADECEMOS LA ATENCIÓN PRESTADA.

RECIBA NUESTRO MAS CORDIAL SALUDO."

BIENVENIDOS A DUTXALIUM.

DUTXALIUM ES DISTRIBUIDOR AUTORIZADO
DE LAS SIGUIENTES FIRMAS:

spaziati

HÔME
& bath

f
facebath

hidroglass
mamparas baño/ducha

STEEL
BATH
MAMPARAS ACEROINOX

AKUA
BATH

Infinity
Professional

FER-LO PIEDRA
PIEDRA NATURAL Y PLATOS DE DUCHA



IMEX
PRODUCTS

Oxodesign®

artyson





DUTXALIUM[®]

Gerencia: Manuel Rodríguez 610 055 398

D. Comercial: Enrique Rodríguez 622 370 882

Mail: info@dutxalium.com

www.dutxalium.com